



THE VAUXHALL COLLEGE

***Multi-Valve -2
V6 Engines***



THE VAUXHALL COLLEGE

THIS HANDOUT MATERIAL IS VALID
AT TIME OF ISSUE,
BUT WILL NOT BE UPDATED BY
VAUXHALL COLLEGE
IN THE EVENT OF CHANGE



THE VAUXHALL COLLEGE

With the ever increasing competition in the retail vehicle marketplace customers are offered more choice and more competitive pricing. To win new customers and more importantly keep existing customers Vauxhall have introduced THE VAUXHALL DIFFERENCE which, with your help, will ensure:-

EVERYONE ENTHUSIASTIC ABOUT VAUXHALL

For us in Aftersales this means that we must take a fresh look at the way we do things, especially when dealing with *our* customers.

We must change from the *Old Game*, that we have been used to for so long, to the *New Way* which may stretch our *Comfort Zones* more than we would like.

REMEMBER. *If you always do what you've always done,
you'll always get what you've always got.*

Aftersales Training courses at *The Vauxhall College* are designed to help you think *The New Way*, and back at your Retailer, help you to achieve *Total Customer Enthusiasm* by exceeding their expectations.

The most important *Difference* the Technician can make when *Working with the Retailer Team* towards customer enthusiasm is:-

FIX IT RIGHT THE FIRST TIME !

Some important *Moments of Truth* that influence our customers' *Point of View* and can easily be overlooked are:-

- Always use protective covers.
- If the battery has been disconnected or discharged always re-programme the electronically controlled windows and sliding roof, reset the clock to the correct time and if possible re-code the radio.
- Never smoke in customers' vehicles and, unless necessary, never interfere with the vehicle contents. Always restore the radio to the original station and volume settings.
- When on road test treat the vehicle with respect - you may be observed.
- When dealing with customers directly treat them with respect and be polite.

REMEMBER. *If you were the customer you would expect it!*

With your sustained efforts *The Vauxhall Difference* will succeed.

Your role is vital. We need ***you*** to make it work.



Vauxhall College - Multi-Valve V6 Engine

Introduction

The training workbook is designed in logical steps to help the Vauxhall Technician understand the working principles and overhaul procedures of **Multi-Valve 2 (V6) Engines** as fitted to Vauxhall cars.

To gain full benefit from the book it must be used in conjunction with the appropriate training course.

Produced and Printed by:-
Meridian Training Services Limited
© Vauxhall Motors

Vauxhall College - Multi-Valve V6 Engine

Table of Contents

	Page No
Section One	
Special Service Tools	2
Section Two	
Features C25 XE	2
Section Three	
Engine Technical Data	2-3
Section Four	
Complete Engine Stripdown	2-12
Section Five	
Component Overhaul and Checks	2-5
Section Six	
Complete Engine Rebuild	2-18
Section Seven	
Engine Specifications	2
Section Eight	
Wiring Diagram	2
Section Nine	
X 25 XE and X 30 XE Engines Longitudinal Installation - Omega B	2-12
Section Ten	
X25 XE Engine, Transverse Installation - Vectra B	2-5
Section Eleven	
Exhaust Gas Recirculation System, Secondary Air Injection Multi-Ram Air System,	2-13













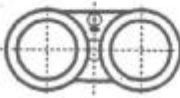





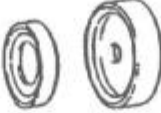





Vauxhall College - Multi-Valve V6 Engine

Section 1

Special Service Tools

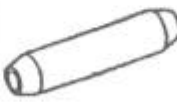
Vauxhall College - Multi-Valve V6 Engine

Special Tools

KM-800-1 (1+2) Camshaft drive holding tool		KM-498 Oil pressure check gauge		KM-667 Vacuum hand pump	
KM-800-20 Checking device camshaft drive		MKM-604-A Torx socket set		KM-693 Front crankshaft seal installer	
KM-800-2 (3+4) Camshaft drive holding tool		MKM-604-21 Toothed belt drive gear bolt socket		KM-J-34730-1 Fuel pressure checking gauge	
KM-800-10 TDC-Adjusting tool		KM-635 Crankshaft rear seal installer (use with KM 535)		KM 340-7 Valve seat cutter guide (use with KM340- 12 & KM340-26)	
KM-135 Oil Pressure check adaptor (Use with KM 498)		KM-652 Fly wheel locking device		KM340-12 30°/45° Valve seat cutter (use with KM 340- 7)	
KM-194B Spark plug wrench		KM-653 Valve spring compressor adaptor		KM 340-26 60° Valve seat cutter (use with KM 340- 7)	
KM-422 Camshaft seal installer		KM 662 Toothed belt drive gear holding wrench		KM-348 Valve spring compressor (use with KM 653)	
KM-470 Angular torque wrench for cylinder head bolts		KM-835 Valve stem oil seal installer		KM-412 Engine overhaul stand	
KM-471 Cooling pressure checking adaptor		KM-805 Valve guide reamer			

Vauxhall College - Multi-Valve V6 Engine

Section 2

Features

C25XE

Cavalier / Calibra

Vauxhall College - Multi-Valve V6 Engine

C25XE V6 2.5 Litre Engine (24V)

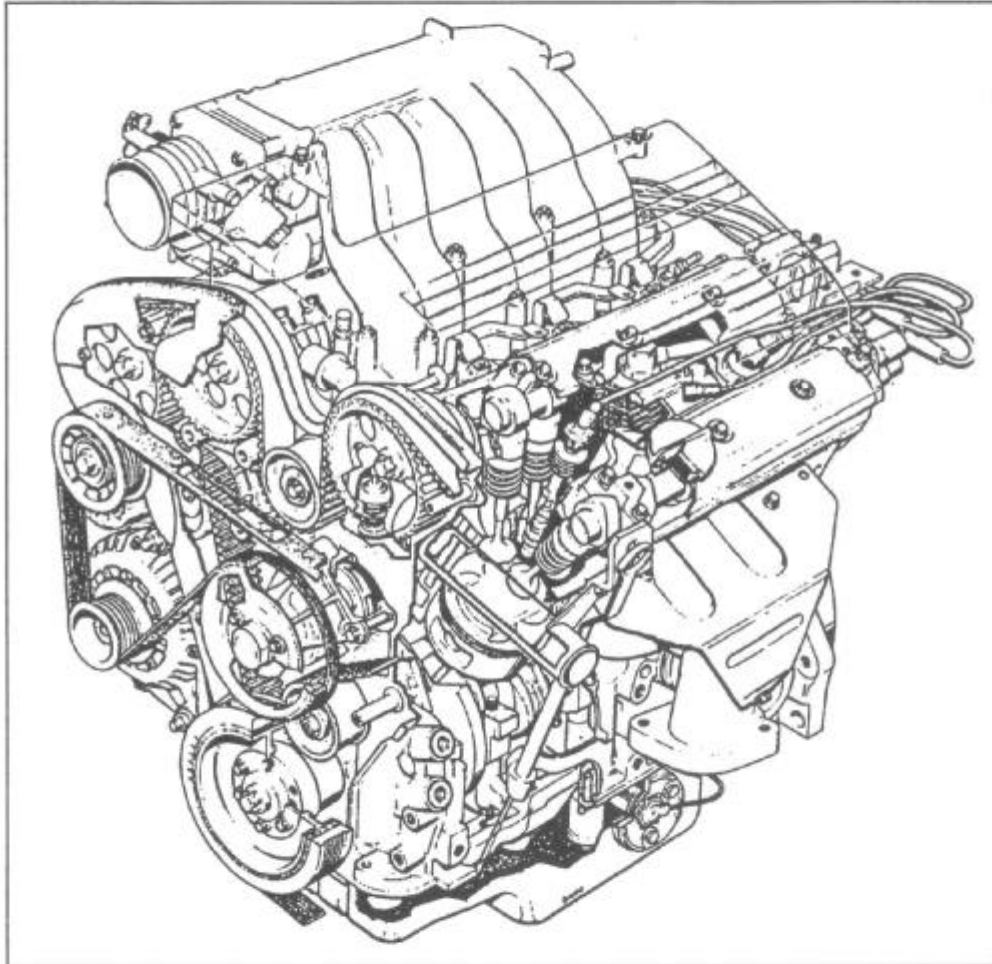

Important advantages of the 2.5 litre engine are:-

- Compact design
- Low weight
- Low noise radiation
- Improved quietness
- High fuel economy
- Construction for unleaded premium RON 95
- Knock control on both cylinder sides
- Optimisation of the engine design

Vauxhall College - Multi-Valve V6 Engine

Section 3

Engine Technical Data

Vauxhall College - Multi-Valve V6 Engine

Engine Technical Data

Engine	Model
C25XE	Cavalier

Designation	C25XE
Displacement	2498 ccm
Output	125 kw/6000 rpm
Torque	227 Nm/4200 rpm
Compression Ration	10.8:1
Bore	81.6 mm
Stroke	79.6 mm
Cylinder Angle	54°
Engine Weight	176 kg
Max Speed	145 mph
Fuel	RON 95 Unleaded
Idle	600 RPM

Vauxhall College - Multi-Valve V6 Engine

2.5 V6 Engine Torque Curve

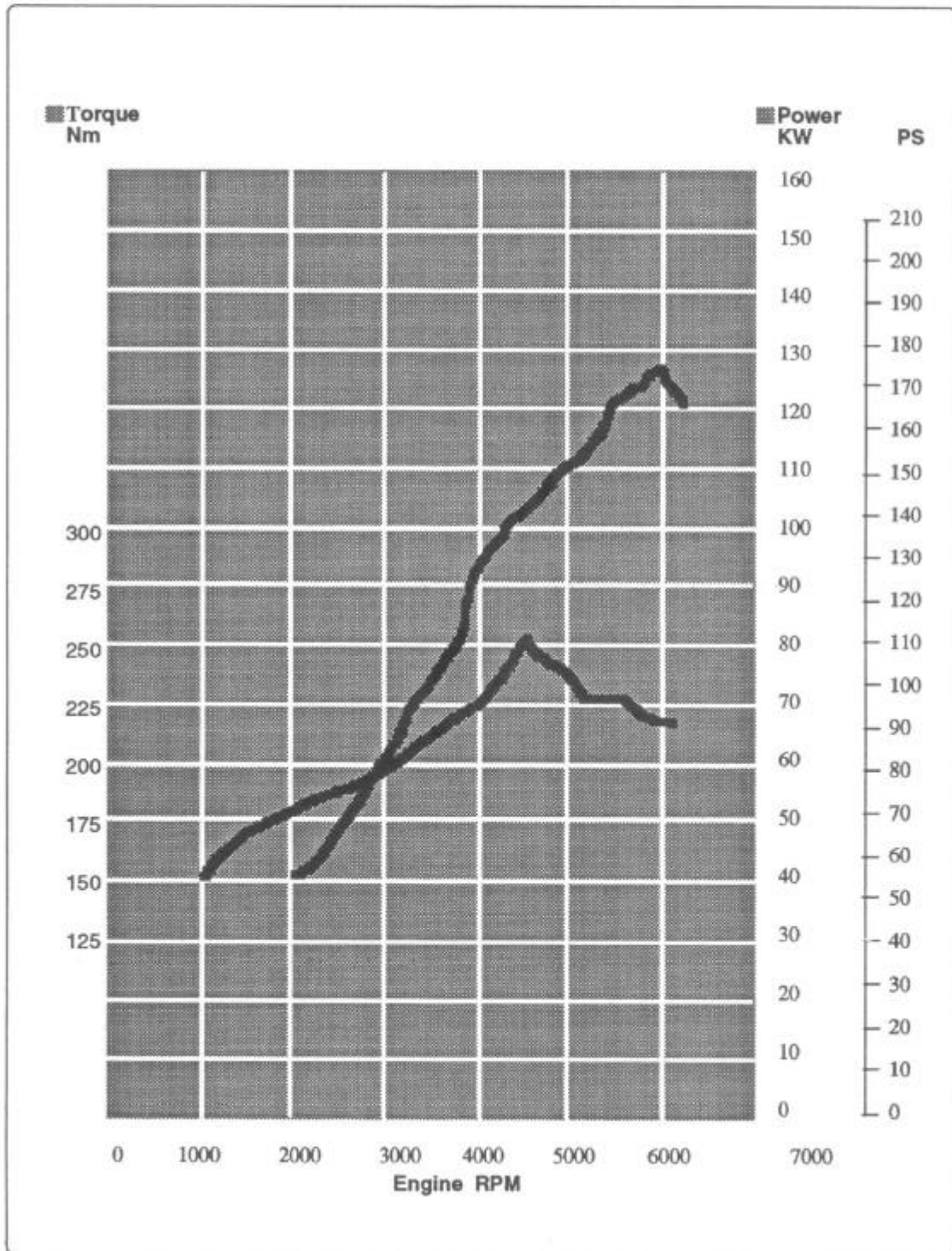

Vauxhall College - Multi-Valve V6 Engine

Section 4

Complete Engine Stripdown

C25XE

Cavalier / Calibra

Vauxhall College - Multi-Valve V6 Engine

Install engine onto overhaul stand (KM 412) and drain all engine oil and coolant.

Remove Poly v belt and Cover.

Loosen 3 screws of power steering pump drive wheel, using the appropriate wrench release belt tension at tensioner and remove poly 'V' belt.

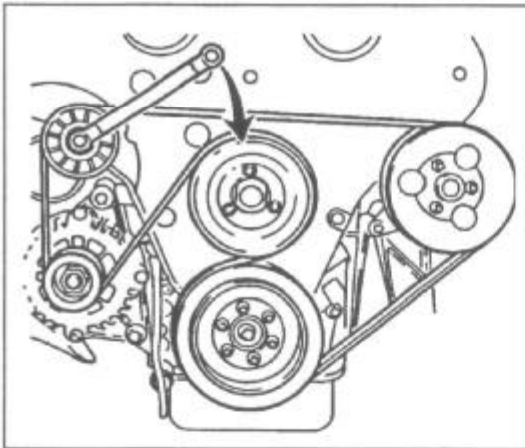

Remove water pump and steering pump pulleys, remove tensioner and support.

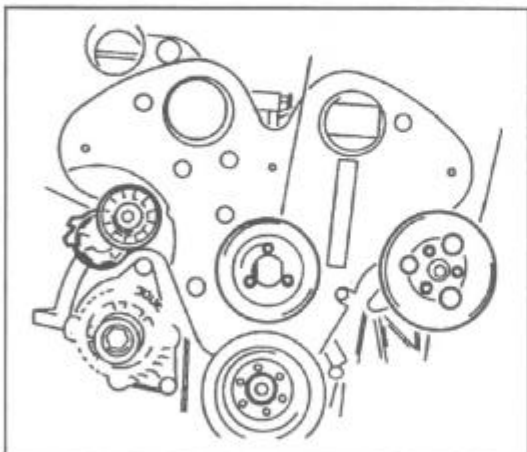

Remove the holding screws and take off the tooth belt cover.

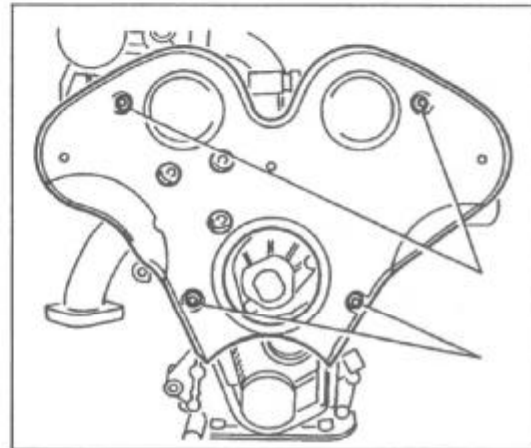

Remove Clutch/Flywheel or Flexplate

Remove clutch assembly. Using holding tool KM 652, remove flywheel or flexplate.

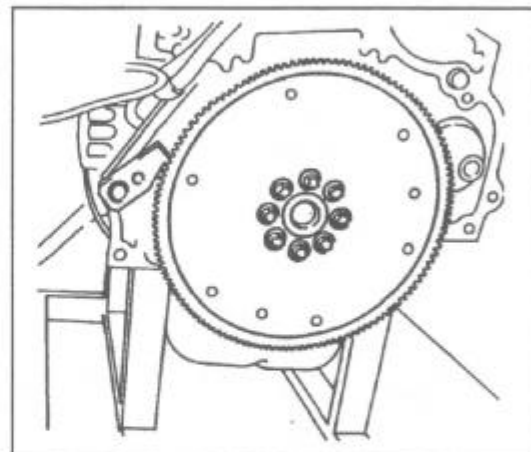

Vauxhall College - Multi-Valve V6 Engine

Remove Intake Manifold

Loosen all hose, cable and coolant connections.

Remove idle air speed adjuster cable etc., Remove throttle valve potentiometer and E.T.C. cables. Remove vacuum hoses.

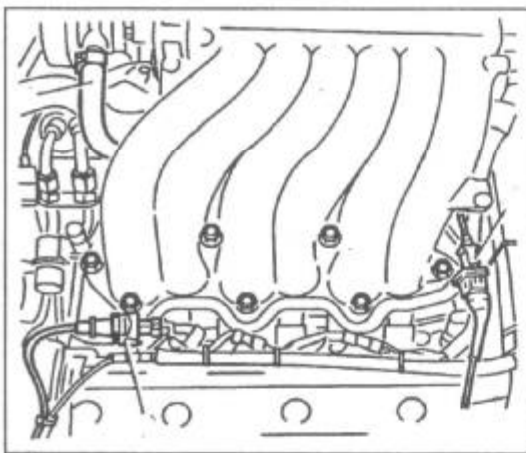

Unscrew and remove intake manifold upper part.

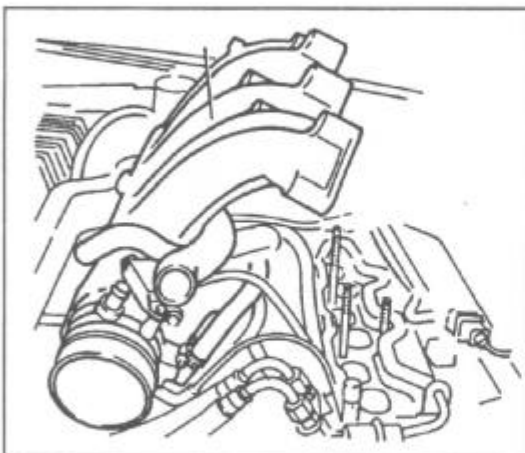

Remove Ignition Cables/Spark Plugs

Remove ignition coil, ignition cables and spark plugs.

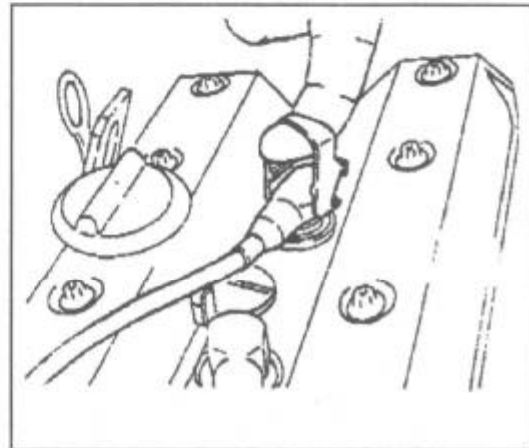

Note: Cylinder numbers are stamped on right hand valve cover (see diagram below)

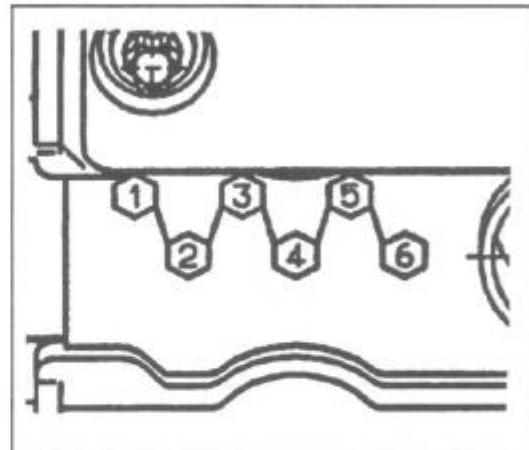

Firing order 1-2-3-4-5-6.

Vauxhall College - Multi-Valve V6 Engine

Remove Injector Valves

Remove fuel intake lines with injector valves and disconnect injector valves.

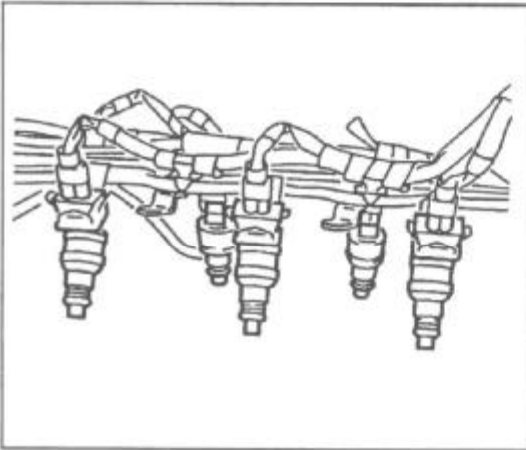

Take off injector clamps and remove pipes. Remove holding bolts and take off manifold centre part.

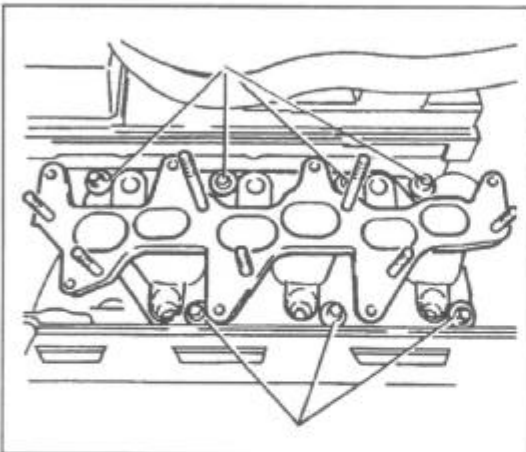

Remove Thermostat and Housing

Unscrew side pipe and remove thermostat housing extension tube.

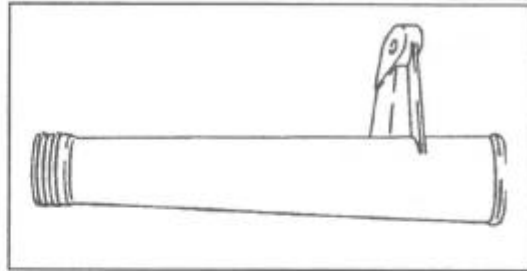
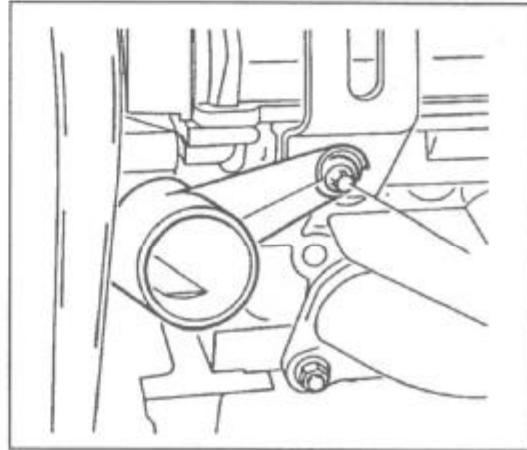

Unscrew lower part of intake manifold and remove.

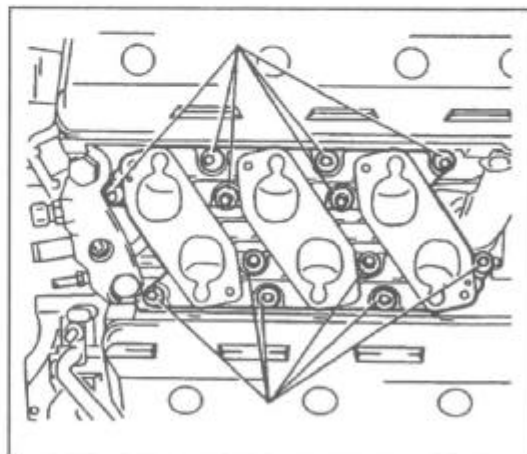

Vauxhall College - Multi-Valve V6 Engine

Unscrew and remove thermostat housing, take out thermostat by pressing it and twisting (bayonet fit).

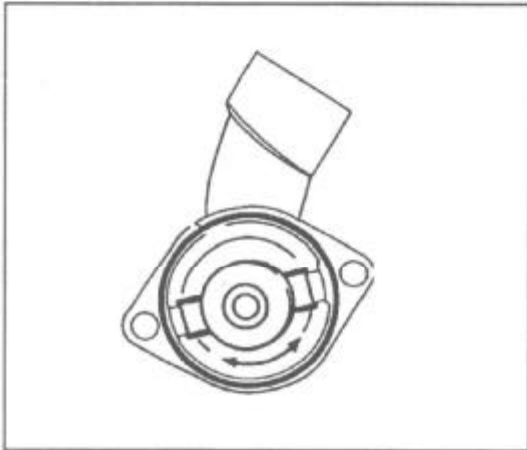

Unscrew and remove crankshaft pulley.

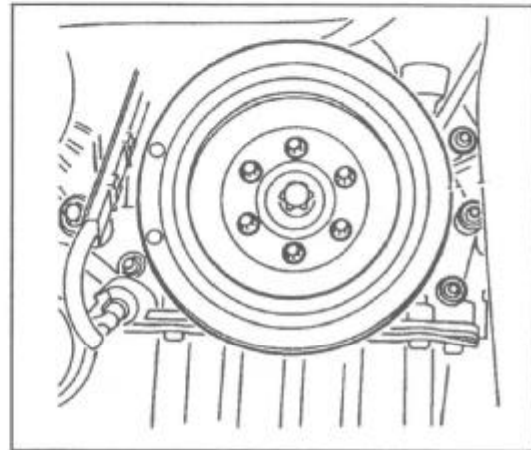

Remove tooth belt.

Remove Tooth Belt

Observe running direction of tooth belt and loosen tooth belt tensioner

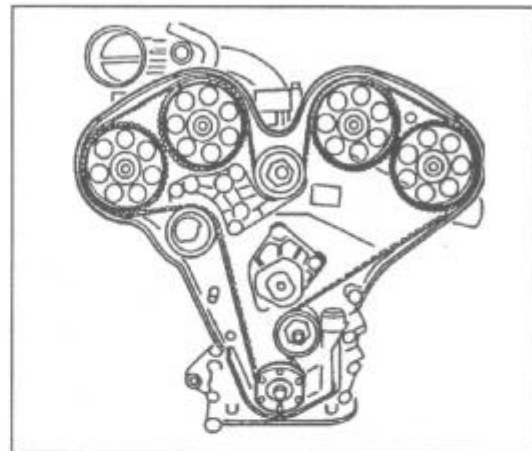
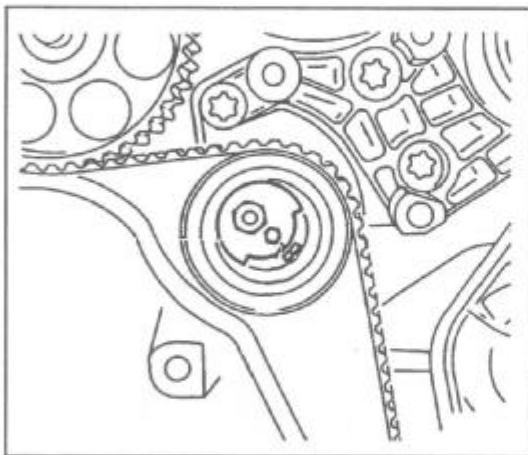

Vauxhall College - Multi-Valve V6 Engine

Remove Rear Tooth Belt Cover

Remove lower idler pulley and tooth belt crankshaft pulley.

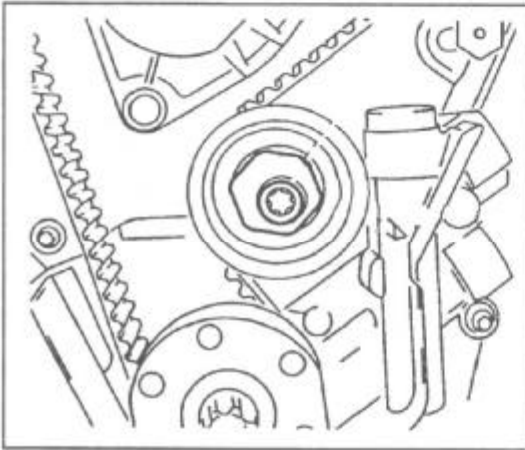

Remove water pump.

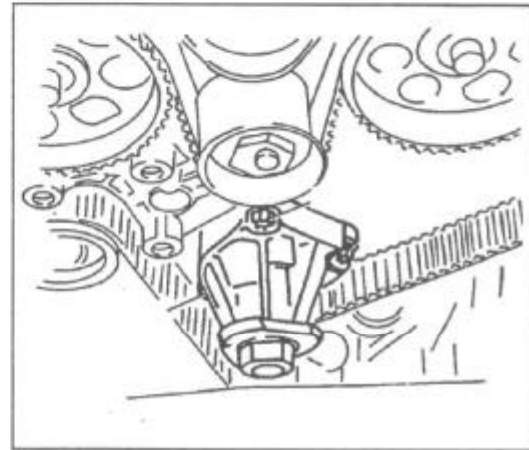

Identify left hand and right hand valve covers and remove.

Remove upper idler pulley with tooth belt tensioner and support.

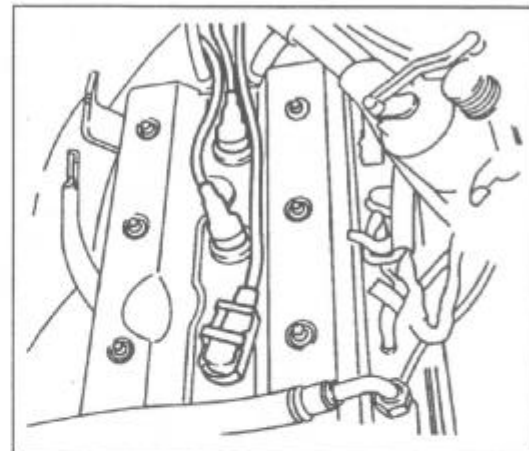
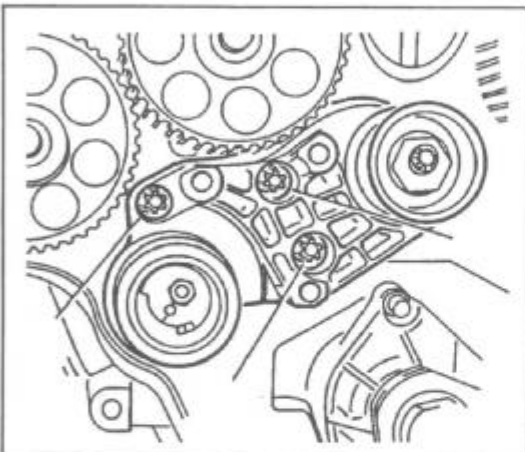

Vauxhall College - Multi-Valve V6 Engine

Identify right hand and left hand camshaft pulleys and using a holding wrench on camshafts remove all four pulleys.

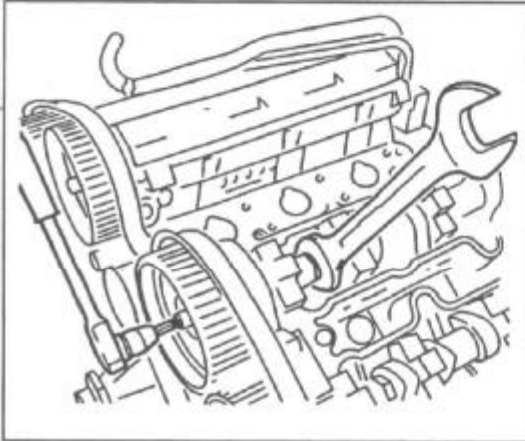

Unscrew holding screws and remove rear tooth belt cover.

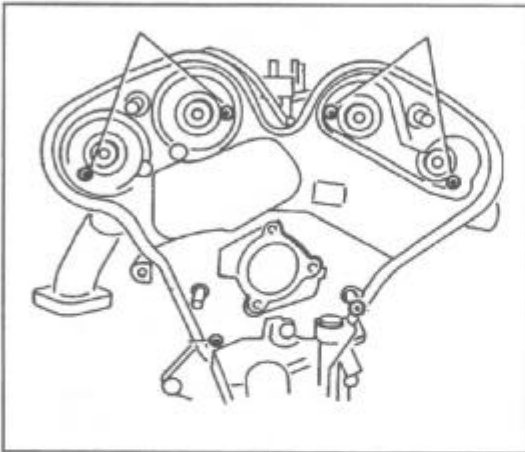

Remove Cylinder Heads

Remove coolant connection bridge.

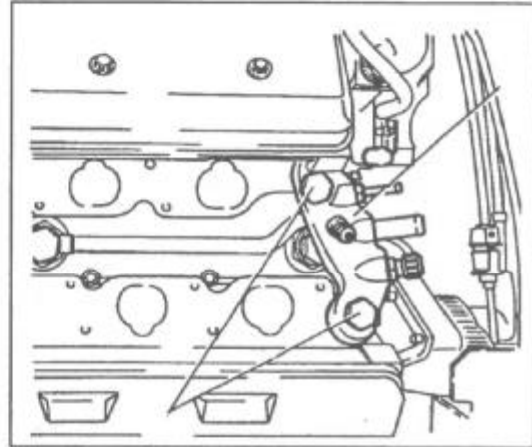

Before removing camshaft bearing caps observe the markings on the caps and the corresponding marks on the cylinder heads.

Left Hand Cylinder Head

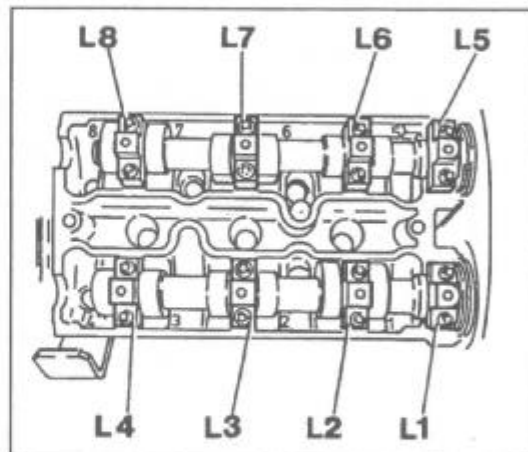

Vauxhall College - Multi-Valve V6 Engine

Right Hand Cylinder Head

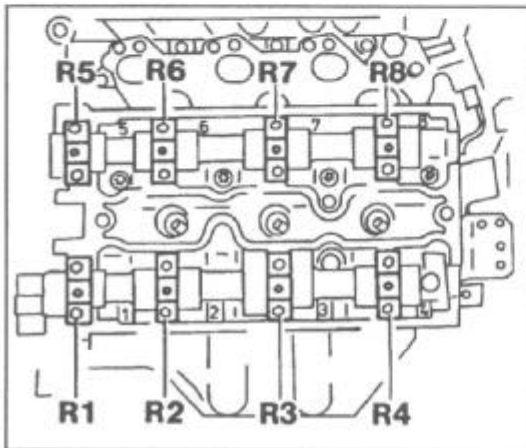

Remove exhaust camshafts, (ensuring that the bearing cap screws are loosened carefully and in several stages to prevent the possibility of breakage occurring to exhaust camshafts).

Loosen and remove cylinder head bolts in small stages. (Loosening sequence is from the outside inwards in a spiral pattern).

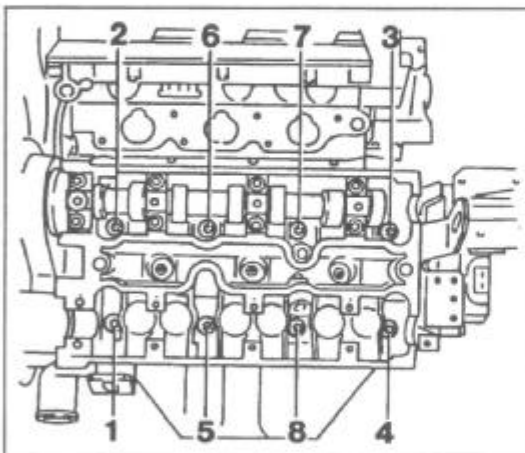

Remove both cylinder heads.

Note: The cylinder identification sensor or phase sensor is located on the first bearing cap of the exhaust camshaft on the right hand cylinder head.

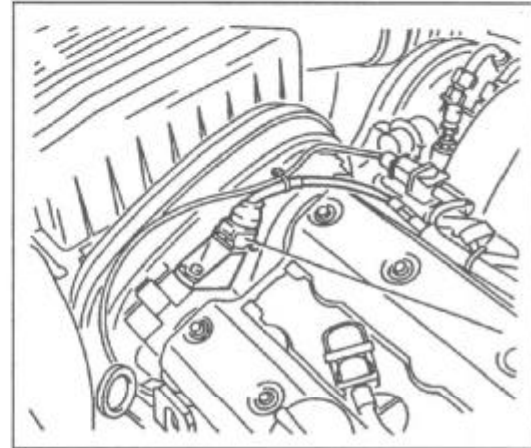

Remove Auxiliary Engine Components

Remove starter.

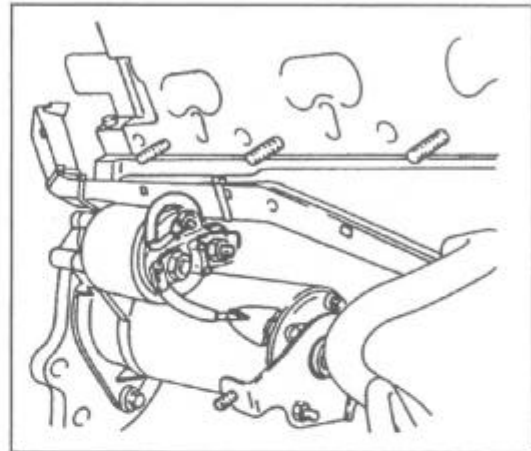

Vauxhall College - Multi-Valve V6 Engine

Remove engine ventilation housing and tank ventilation valve.

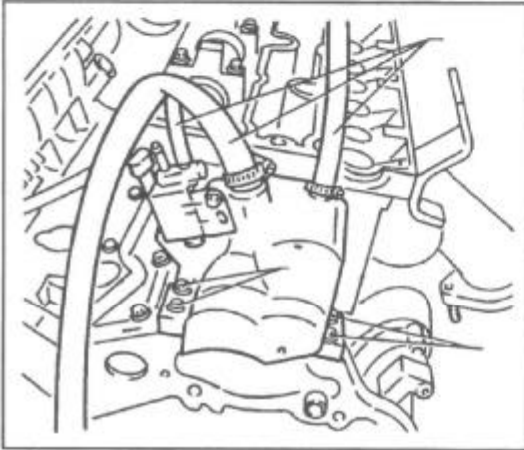

Unscrew and remove oil filter.

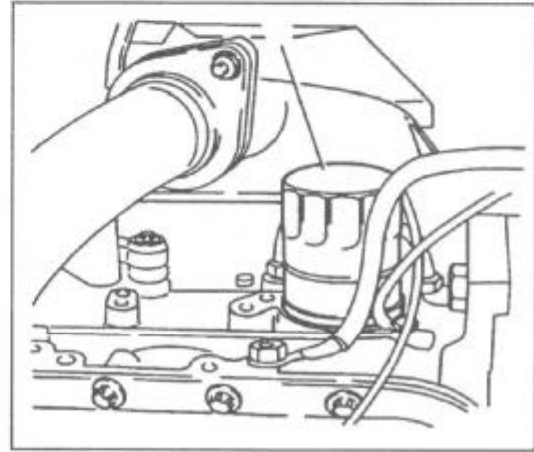

Remove power steering pump with support.

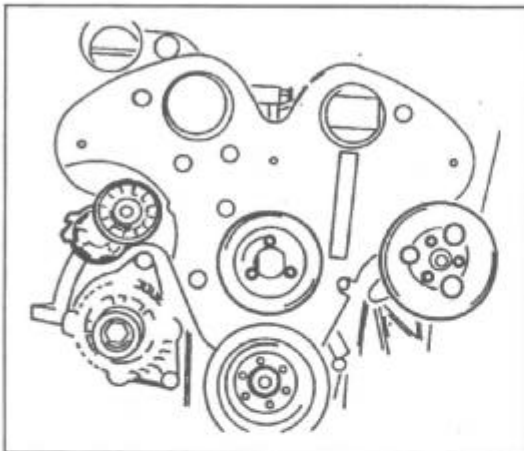

Remove 2 knock sensors.

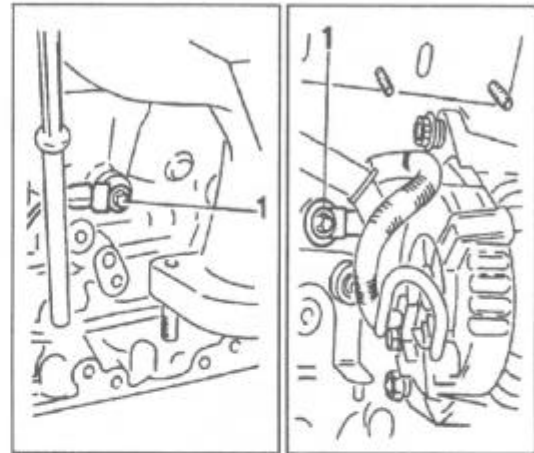

Vauxhall College - Multi-Valve V6 Engine

Remove heat exchanger pipes.

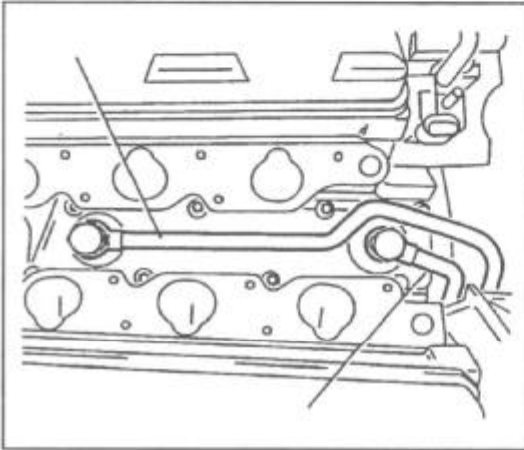

Remove heat exchanger.

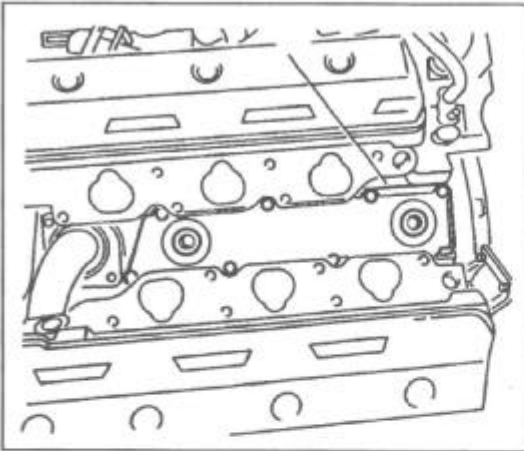

Remove Pistons with Connecting Rods

Unscrew and remove oil pan.

Remove intake pipe and oil protection shield.

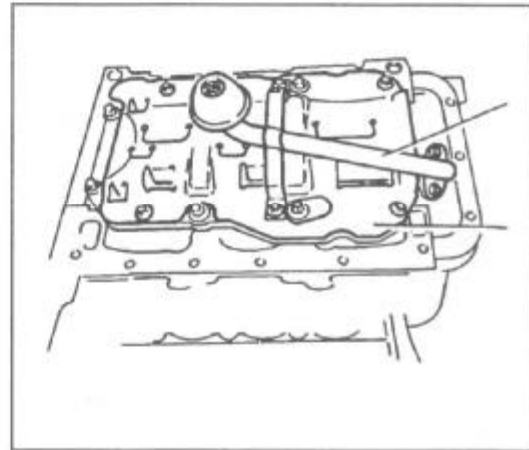

Mark big end bearing caps, unscrew bolts and remove.

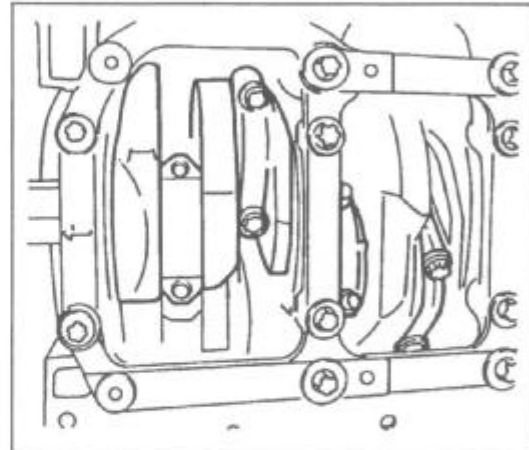

Vauxhall College - Multi-Valve V6 Engine

Number pistons to their respective bore, remove pistons and connecting rods by pressing them out towards the top of the engine block.

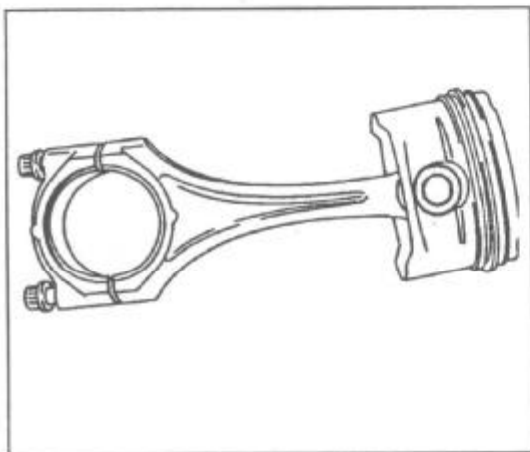

Note: Notched side of connecting rod faces towards flywheel.

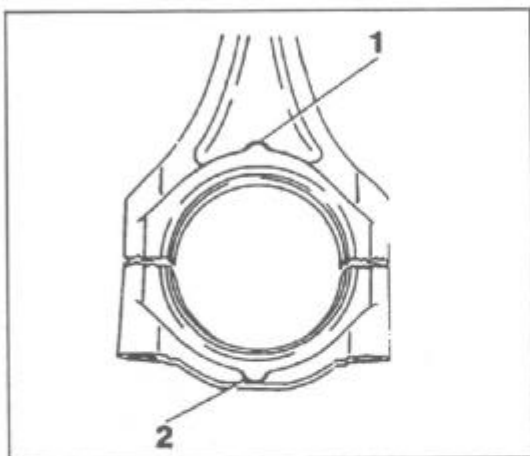

Note: Arrow on piston crown faces towards oil pump

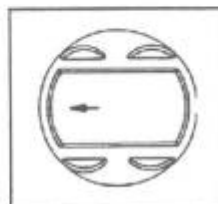

Gudgeon pin is a sliding fit in piston and a press fit in connecting rod.

Take care to avoid damage or dirt ingress in fractured connecting rod faces.

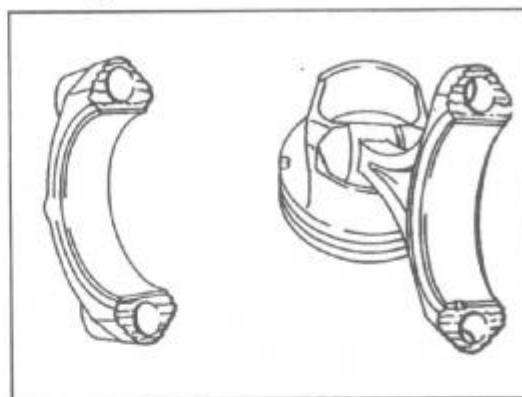

Remove Oil Pump

Unscrew and remove oil pump.

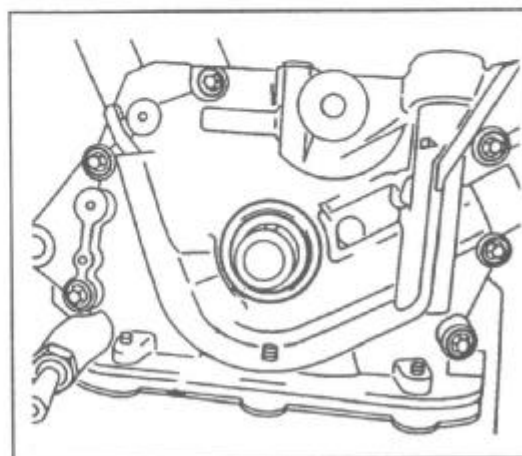

Vauxhall College - Multi-Valve V6 Engine

Remove Crankshaft

Unscrew and remove torsion bridge bolts.

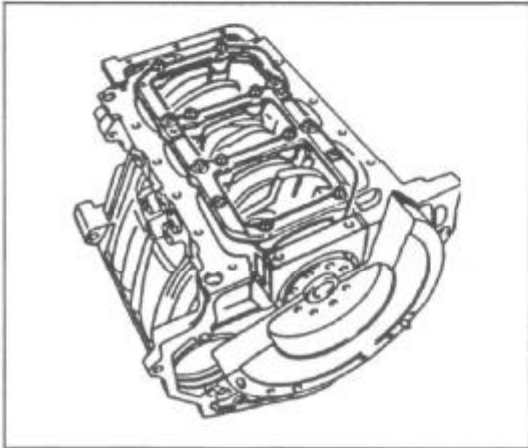

Observe identification marks on main bearing caps.
Unscrew bolts and remove bridge and caps.

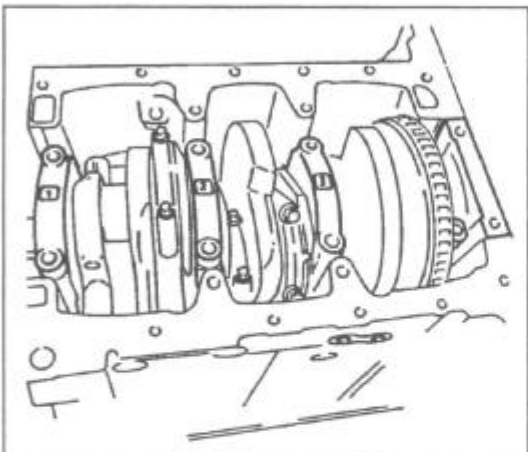

Remove crankshaft.

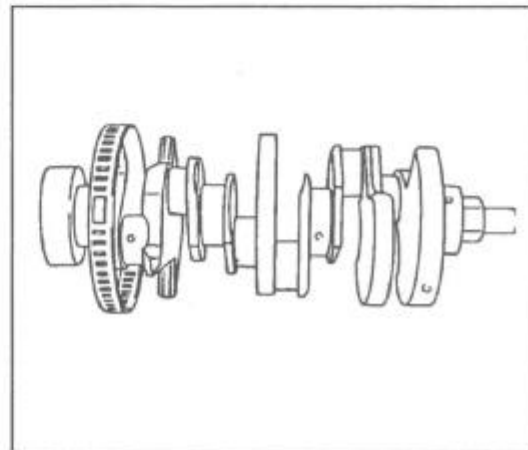

Now the engine is dismantled all parts must be checked for wear and damage.

Renew seals, gaskets and bolts before assembly.

Use only recommended grease and sealants and ensure all surfaces are thoroughly clean before being sealed.

Oil seals may be renewed with the engine assembled.

Vauxhall College - Multi-Valve V6 Engine

Section 5

Component Overhaul and Checks

Vauxhall College - Multi-Valve V6 Engine

Oil Pump - dismantle

Unscrew cover (3) - (mark for installation), and remove oil pump gears.

Remove oil pressure check valve (1) and oil pressure release valve (2).

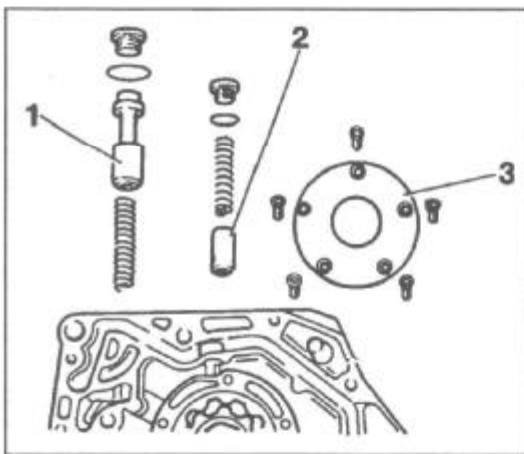

Check and Assemble Oil Pump

Check pump gears for clearance. Check oil pump pressure regulating valve (1) and oil pressure relief valve (2) for free movement.

Install oil pump pressure regulating valve (1) and oil pressure relief valve (2). Install cover (3).

Cylinder Head Dismantle

Observe markings on intake camshaft caps and corresponding marks on cylinder head.

Remove intake camshafts (ensuring bearing cap screws are loosened carefully and in several stages).

Remove valve buckets (keeping them in order). Using valve spring compressor remove valve collets, valves with springs, seats, caps and stem seals.

Cylinder Head Specifications/Checks

Check cylinder head faces for distortion, (max. distortion 0.025 mm). Minimum cylinder head thickness 134 mm.

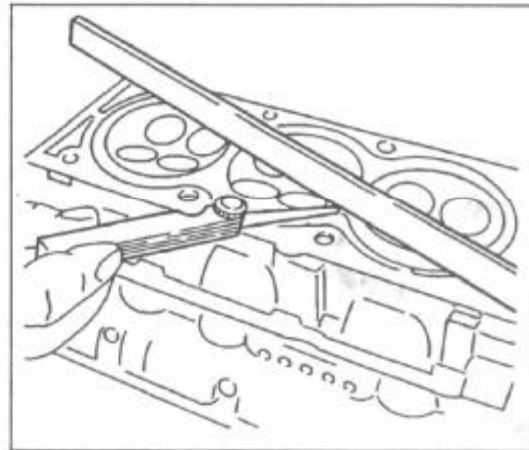

Reface valves, re-cut seats and lap in using grinding paste as necessary.

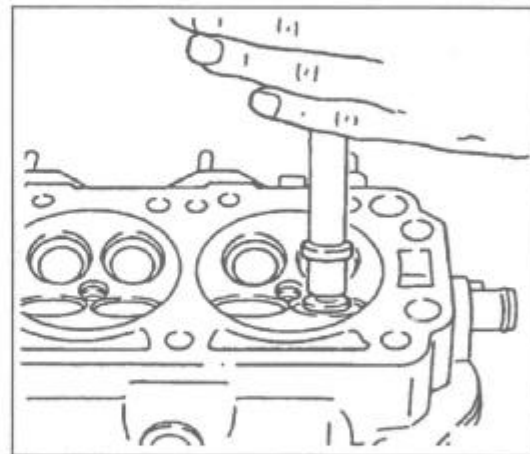

General Technical Data:

- Valve guides and seats are not replaceable.
- Hydraulic valve adjusters are maintenance free.
- Valve seat angle 45° (may be refaced)
- Valve guide bore 6mm

Vauxhall College - Multi-Valve V6 Engine

General Technical Data cont.

Oversize valve stems and valve guide reamers are available (see table below).

Size	Reamer	Identification	
		Production	Service Dept.
Normal		none	K
0.075	KM805	1	K1
0.150		2	K2

Valves with oversize stems and a shorter stem length to allow for valve seat recutting are also available.

Cylinder Head Assemble

Using KM -835 Install stem seals
 Install valve seats, springs, caps
 & collets
 Install valve buckets

Cylinder Block and Crankshaft Specifications/Checks

Check cylinder block faces for distortion. Max. piston protrusion 1.4 mm

Crankshaft may be machined to two undersizes.

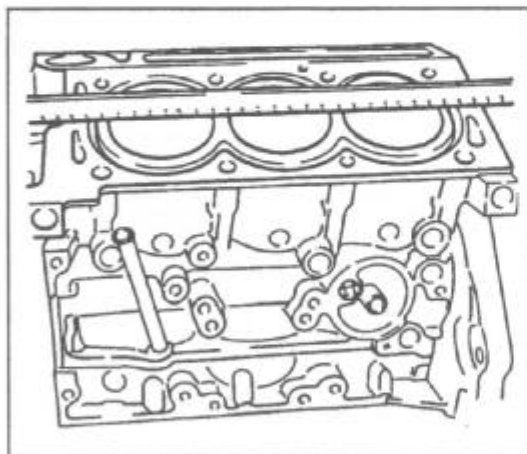

Main Bearings -0.25 and -0.5 mm
 Crankpins -0.25 and -0.5 mm

Rear (unidentified) main bearing cap incorporates the thrust faces.

No. 2 and 3 main bearing shells have **no oil groove** in cap side.

Crankshaft main bearing caps are numbered 1, 2, 3 from the front, the rear bearing cap is not identified.

On the cylinder block corresponding to each crankshaft main bearing cap is a stamping of either 0 or 1. This indicates the size and colour of each respective crankshaft main bearing shell to be installed.

Before installation of the crankshaft into cylinder

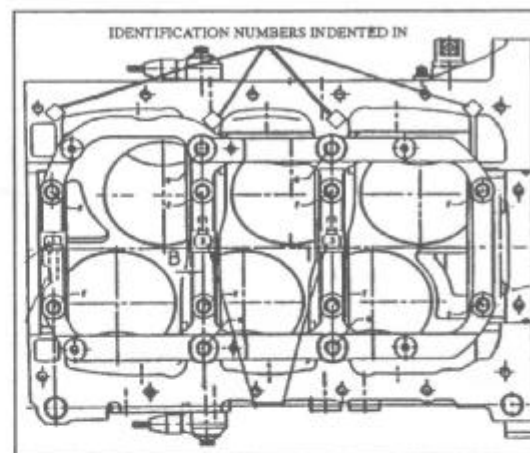

block the sizes and colours of all respective crankshaft main bearing shells must be determined by referring to the appropriate chart on the next page

Vauxhall College - Multi-Valve V6 Engine

Brown
Block
Cap
Green

Crankshaft Main Bearing Sizes SELECTIVE FITS

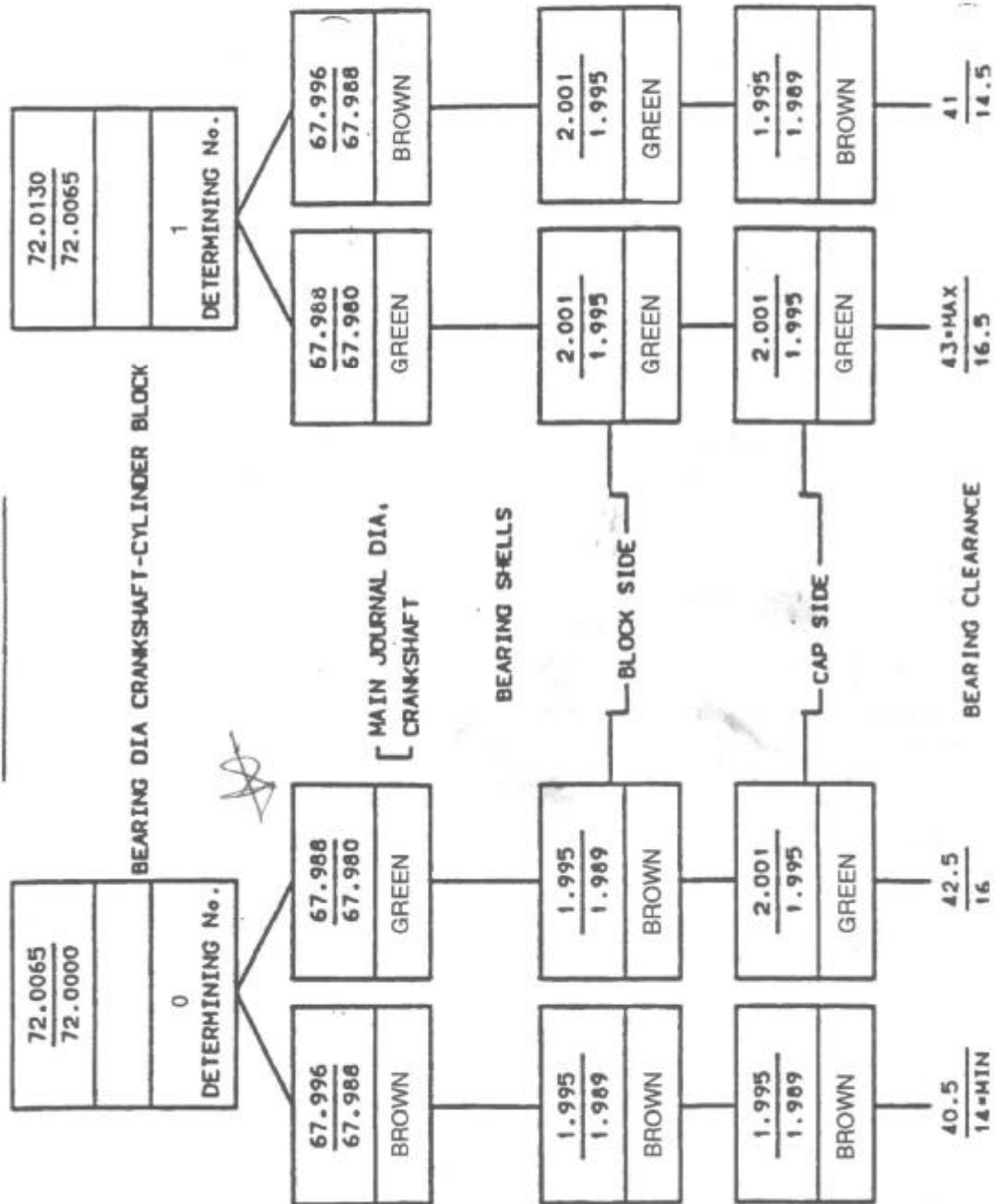

Vauxhall College - Multi-Valve V6 Engine

Cylinder Bore and Piston Specifications/Check

The cylinder bore sizes are marked on the block face corresponding to the bores.

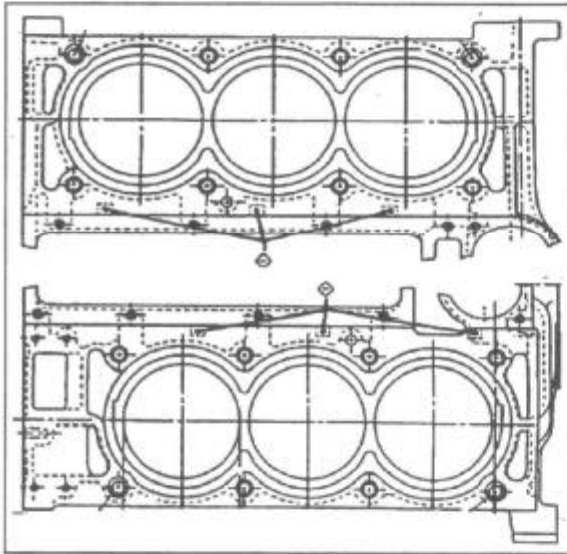

Pistons are marked with a size on the crown for selective fit into cylinder bore.

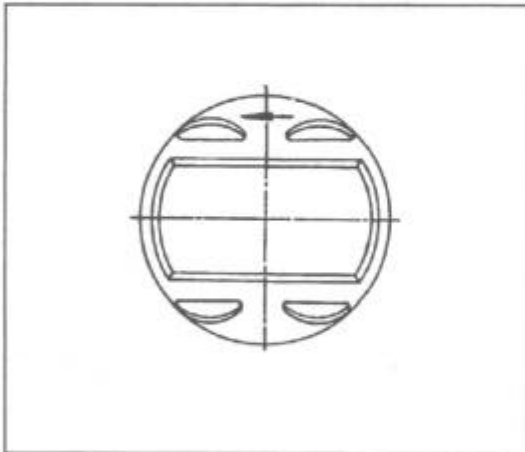

Refer to the following table to determine selective fit sizes.

Size	Marking No.	Cylinder	Piston
1		Above-To	Above-To
	8	81.575-81.585	81.540-81.550
	99	81.585-81.595	81.550-81.560
	00	81.595-81.605	81.560-81.570
2	01	81.605-81.615	81.570-81.580
	02	81.615-81.625	81.580-81.590
oversize +0.5	7+0.5	82.065-82.075	82.030-82.040
	8+0.5	82.075-82.085	82.040-82.050
	9+0.5	82.085-82.095	82.050-82.060
	0+0.5	82.095-82.105	82.060-82.070

General Technical Data

Pistons are cast aluminium alloy with friction reducing pads.

Piston Rings

Top + compression - white
Centre + taper face - blue - with 'top' marking step to face downwards

Oil Control

Ring + 3 parts

All above rings are available in standard production size and +0.5 mm oversize.

Connecting rods must be of same group in each engine.

Vauxhall College - Multi-Valve V6 Engine

Section 6

Complete Engine Re-build

Vauxhall College - Multi-Valve V6 Engine

Install splash shield underneath ventilation channel in cylinder block.

Install Crankshaft

Using the data in the previous section determine colour and sizes of crankshaft main bearing cylinder and cap shells. In service, fit brown shells into block, green shells into cap. Install bearing shells into cylinder block and install crankshaft.

Install main bearing caps with shells, taking note of marks (no. 2 and 3 cap shells without oil groove).

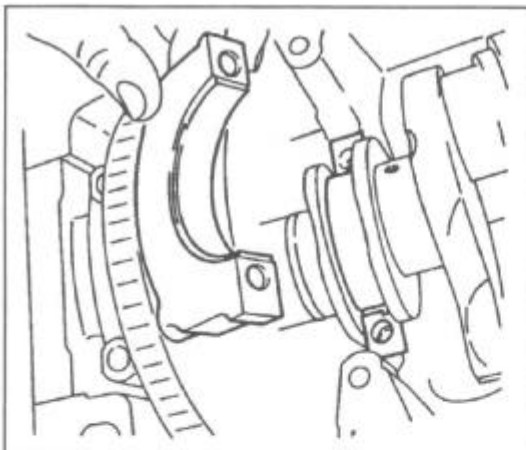

Note: Bearing clearances can be checked using plastigauge (tolerance 0.013 mm - 0.061 mm)



Fit torsion bridge and screw in 8 main bearing cap M10 threaded bolts.

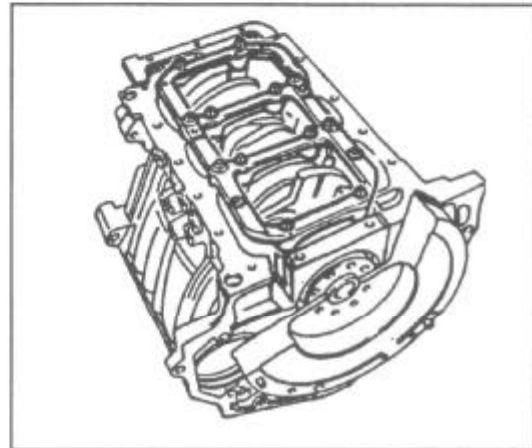

Measure axial play of crankshaft (tolerance 0.1 mm - 0.76 mm).

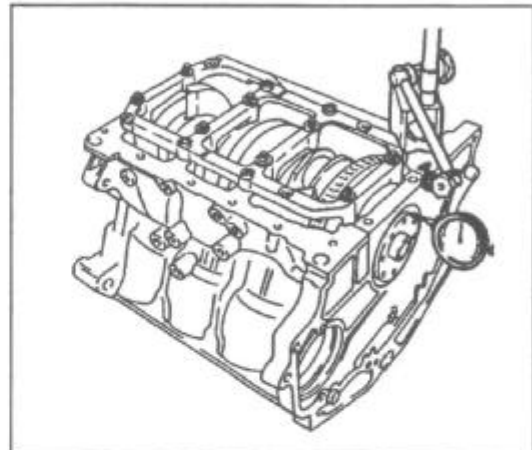

Vauxhall College - Multi-Valve V6 Engine

Screw threaded bushings into bridge until stop, Fasten bridge with 4 M8 threaded screws to the prescribed torque.

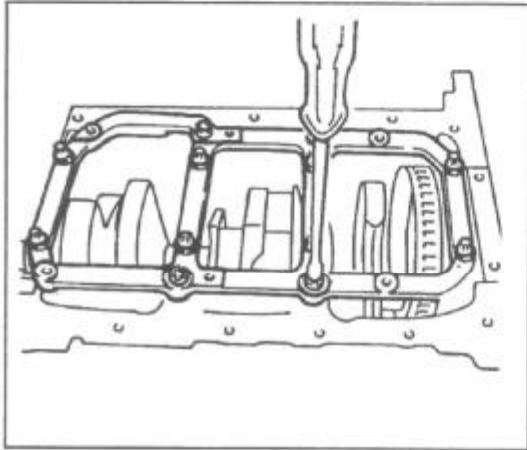

Install Pistons with Connecting Rods

Using the data in the previous section determine piston sizes to bore gradings.

Install piston ring to piston using ring expander (ensure ring gaps are **not** aligned).

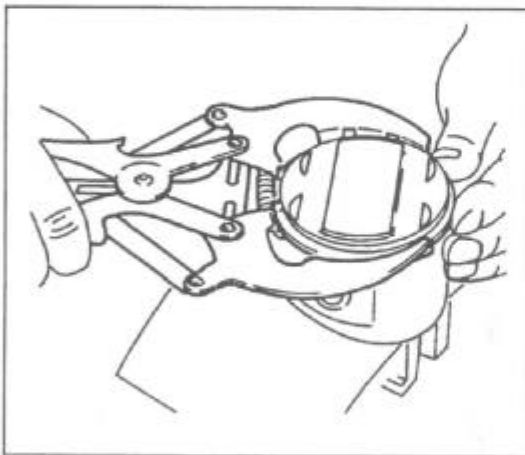

Press pin into conrod, apply bearing shells and using piston ring compressor to compress piston rings insert pistons into cylinder bores.

(Note: **Arrow** on piston crown faces towards oil pump and notched side of connecting rod faces towards flywheel).

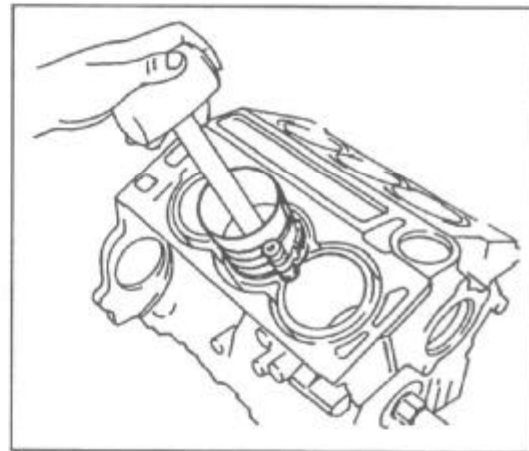

Note: Observe previous markings to ensure pistons are inserted into correct bores.

Install big end bearing caps and tighten bolts.

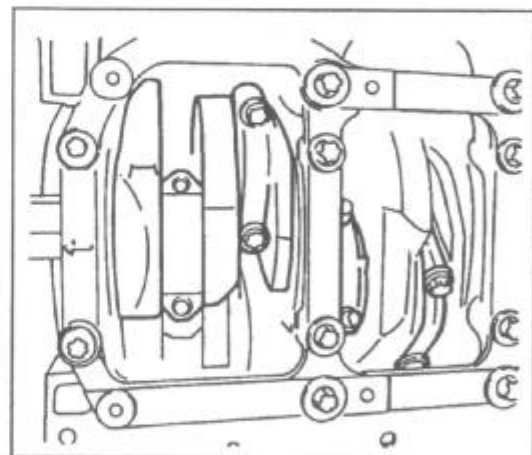

Note: Ensure caps match con rods (observe previous markings).

Vauxhall College - Multi-Valve V6 Engine

Install Oil Pump

Install oil pump to cylinder block.

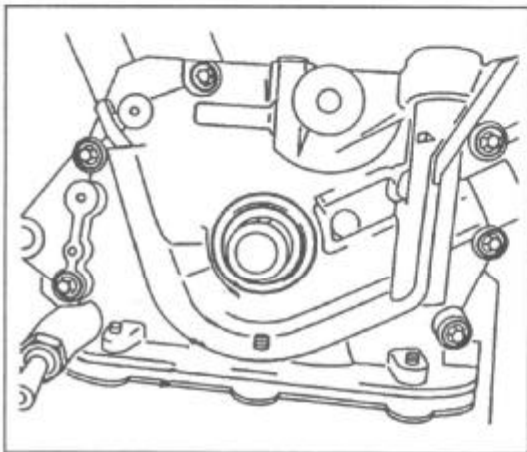

Using KM693 install oil seal.

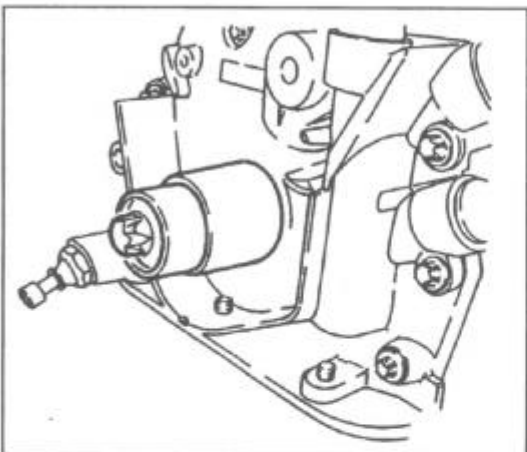

Install spacer ring and toothed belt pulley. Hold pulley with KM 662 and tighten centre bolt to a torque of 250 nm + 45° + 15°.

Grease bolt.

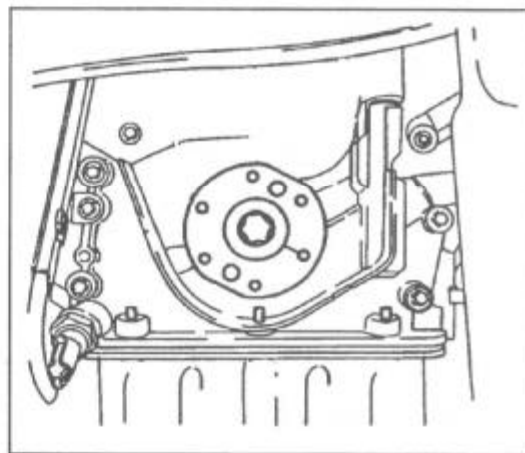

Install Oil Pan

Install oil protection shield and intake pipe.

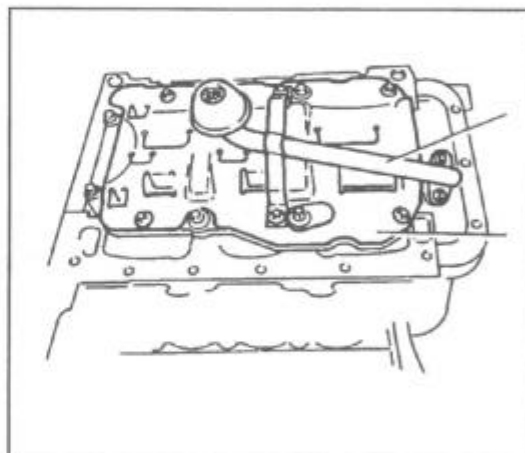

Vauxhall College - Multi-Valve V6 Engine

Install crankshaft rear oil seal using KM 635-1, KM 635-2 and KM 535.

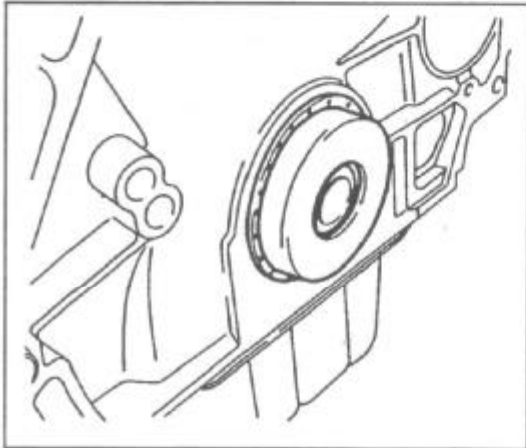

Apply sealer to grooves in rear main bearing cap, ensuring complete penetration.

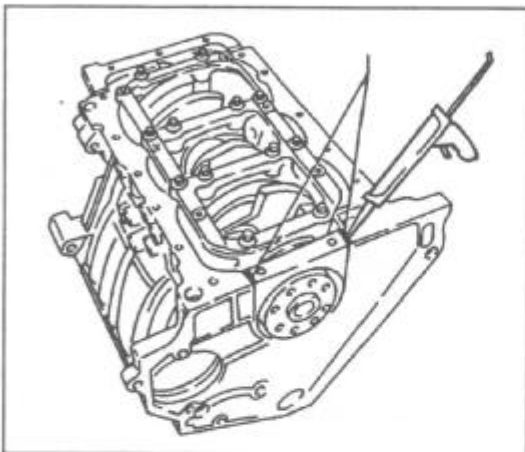

Apply sealer to other areas (1) indicated below.

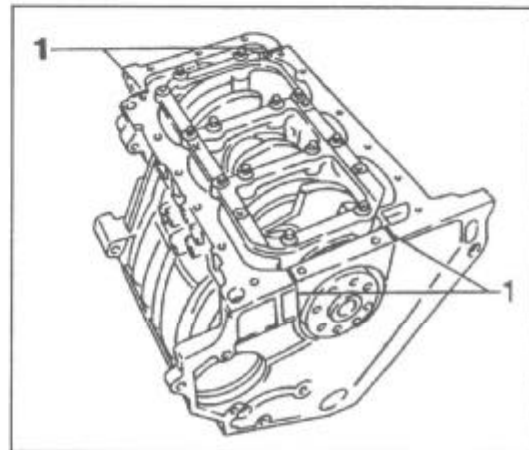

Install oil pan with gasket, tighten bolts to 15Nm in correct sequence.

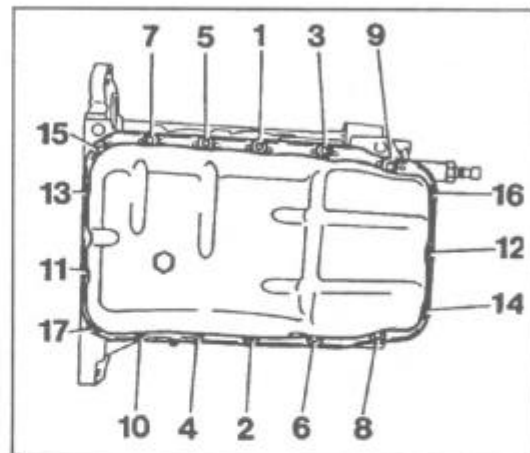

Vauxhall College - Multi-Valve V6 Engine

Turn engine to position no. 1 cylinder at 60° before T.D.C.

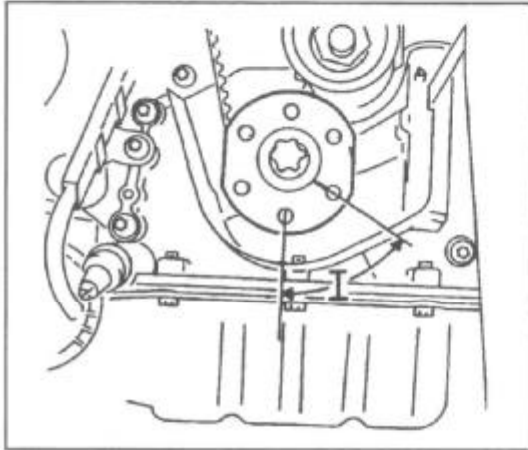

Install Cylinder Heads

Install heat exchanger in V of engine block.

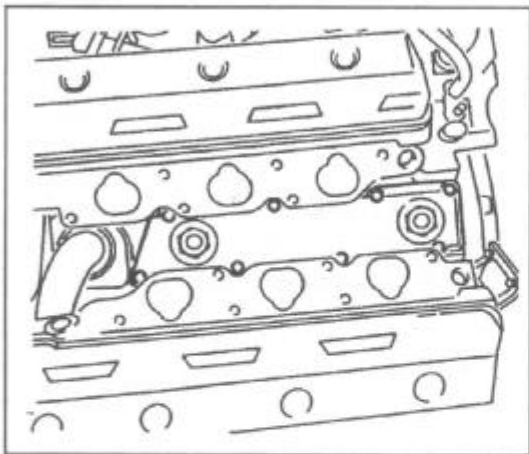

The previous seal ring for the heat exchanger cover is now replaced by a bead of silicon sealing compound (90511124). Apply an approx. 2mm/0.08in (dimension I) thick bead of silicon sealing compound to the groove of the heat exchanger cover and attach immediately (wet).

Heat exchanger cover to heat exchanger 20Nm or 15lb.ft.

Heat exchanger to cylinder block 30Nm/22lb.ft.

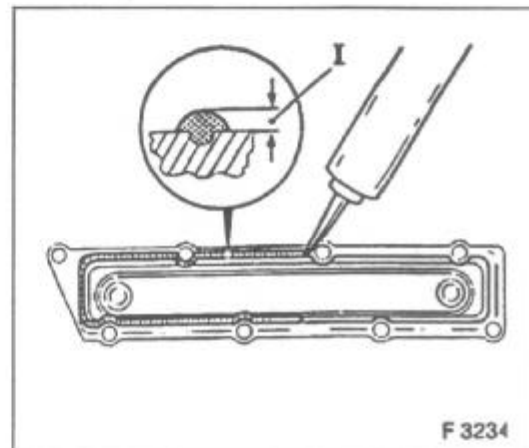

F 3234

Install and connect heat exchanger pipes.

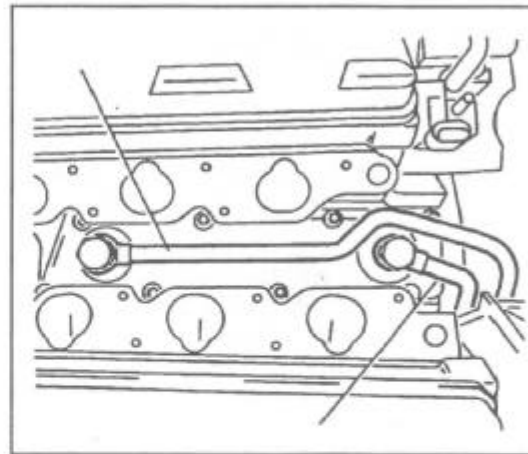

Install new cylinder gaskets to cylinder block.

(Note: Oben/Top marks)

*one forwards R/H
one Backwards L/H.*

Vauxhall College - Multi-Valve V6 Engine

Install cylinder heads and tighten bolts to 25Nm + 90°+90°+90°+15° in a spiral sequence from the middle outwards.

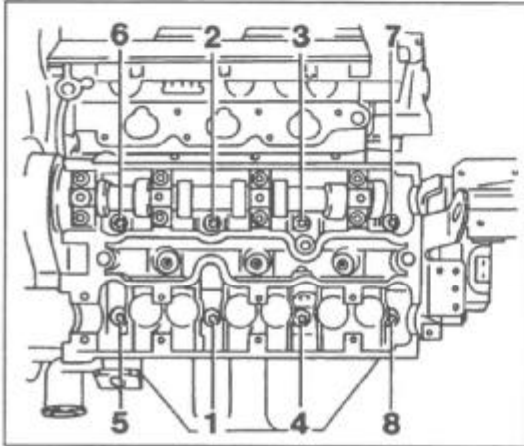

Install intake and exhaust camshafts. Note Camshaft ID Chart. For location of Camshaft ID refer to page 54.

Colour Coding for Cams

V6 'A' Cam	Green	C25XE Inlet & Exhaust X30XE Exhaust
L4 'C' Cam	Blue	C18XE Inlet & Exhaust
V6 'E' Cam	White	X25XE Exhaust
V6 'F' Cam	Brown	X25XE Inlet
V6 'G' Cam	Blue	X30XE Inlet
L4 'H' Cam	Gold	X20XEV Inlet
L4 'I' Cam	Black	X20 XEV Exhaust

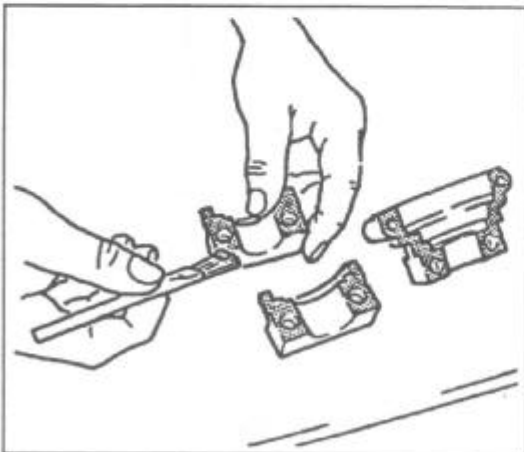

Apply flange sealant (90094714) to front bearing cap faces.

Install all camshaft bearing caps ensuring markings on caps correspond to markings on cylinder head. Tighten cap nuts gradually to a torque of 8 nm. Finally turn camshafts so the end dowel pins are in the positions shown.

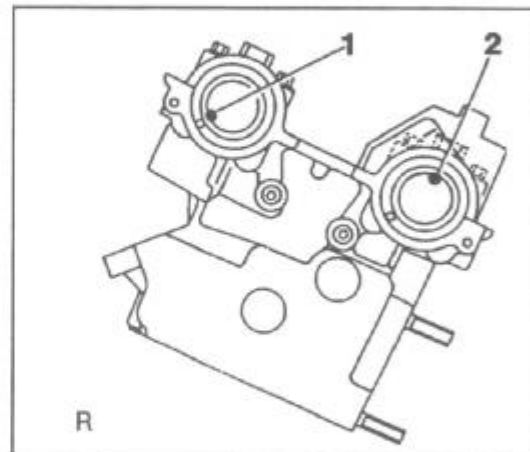
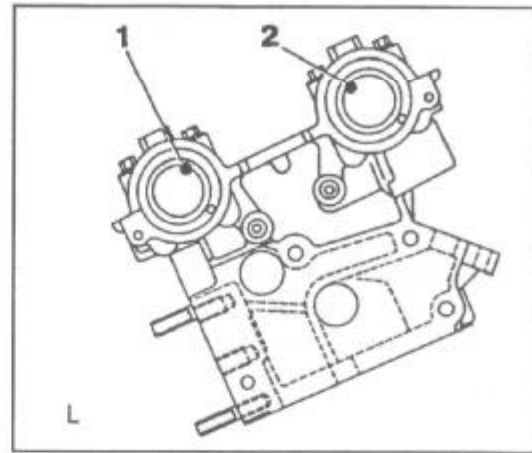

Vauxhall College - Multi-Valve V6 Engine

Install camshaft seals using KM 422.

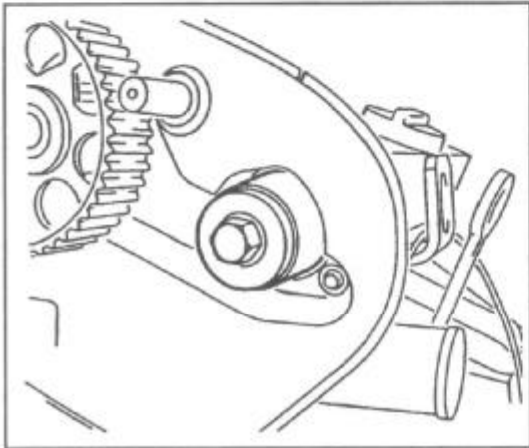

Install thermostat housing and lower interpiece of intake manifold. Thermostat and housing are supplied as one part.

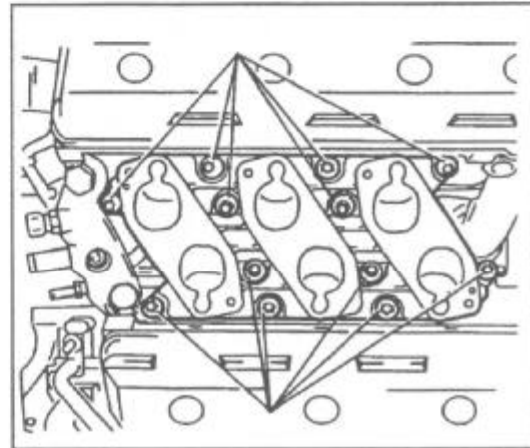

Install Thermostat and Housing

Install thermostat into housing (use new seals).

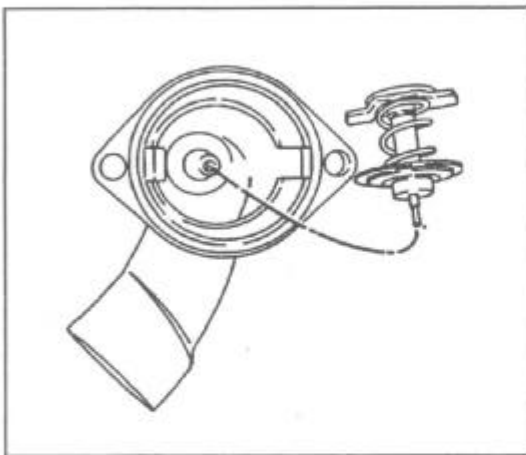

Install thermostat housing extension tube (use new seals).

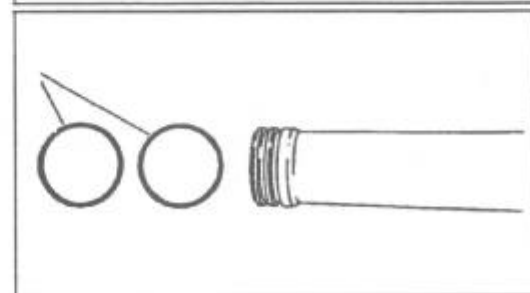
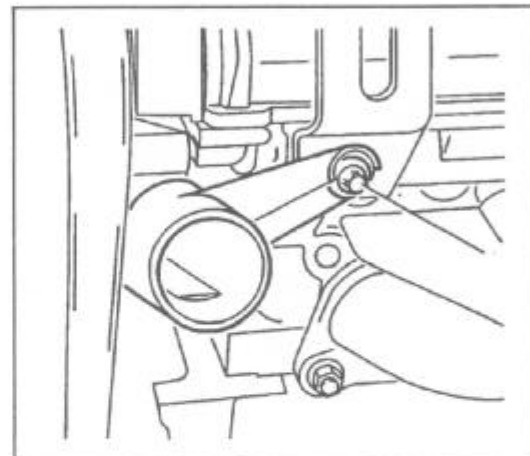

Vauxhall College - Multi-Valve V6 Engine

Install Engine Ventilation and Tank Ventilation

Install engine ventilation gasket and housing, install tank ventilation valve.

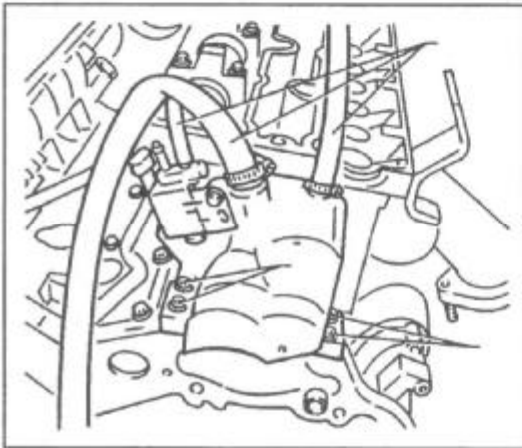

Version with gasket:

Attach engine ventilation with new gasket to cylinder block - 8Nm/lbf. ft.

Version with silicon sealing compound:

Apply an approx. 2mm/0.08in (dimension I) thick bead of silicon sealing compound (90511124) to the groove of the engine vent housing and attach immediately (wet).

Housing to cylinder block 8Nm/6lbf. ft.

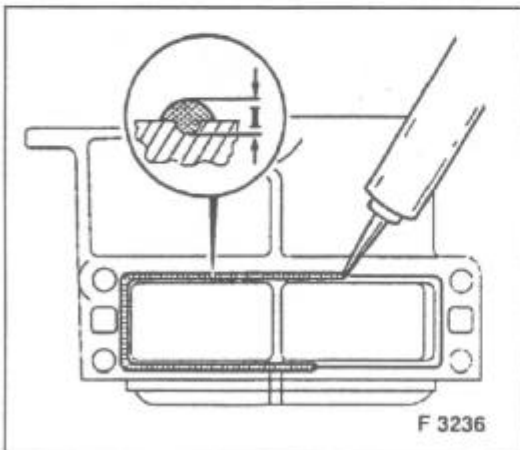

Install Coolant Bridge

Install coolant bridge between cylinder heads using

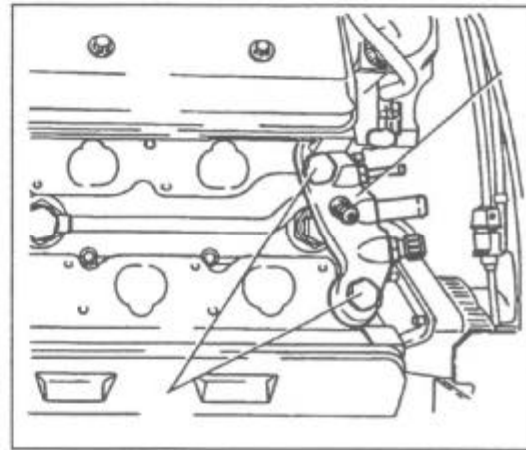

new washers on bolts.

Install Rear Tooth Belt Cover

Install rear tooth belt cover. (Note: Stud above oil pump pressure regulating valve).

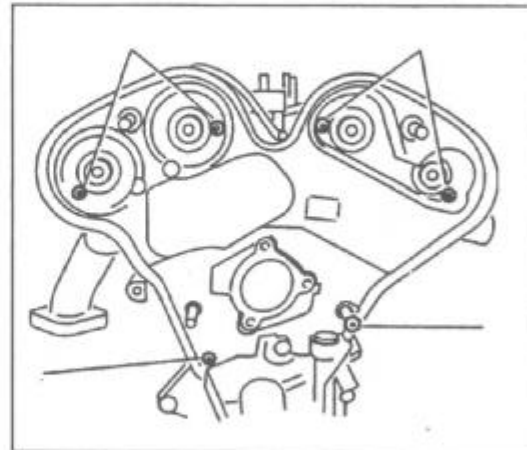

Vauxhall College - Multi-Valve V6 Engine

Install Water Pump, Upper & Lower Rollers

Install water pump, upper idler pulley with tensioner and support and lower idler pulley.

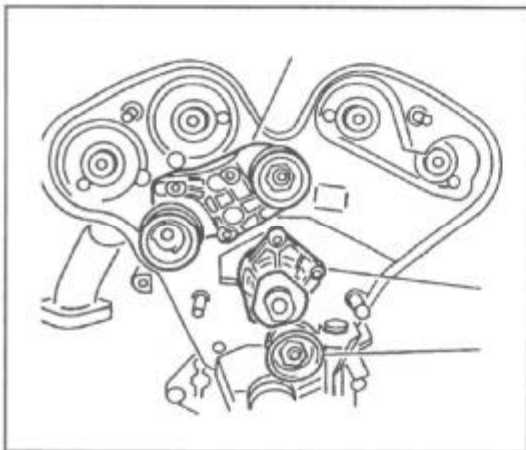

Install camshaft sprocket wheels according to marks. Hold camshafts with wrench and tighten centre sprocket bolts to a torque of 50 Nm + 60° + 15°.

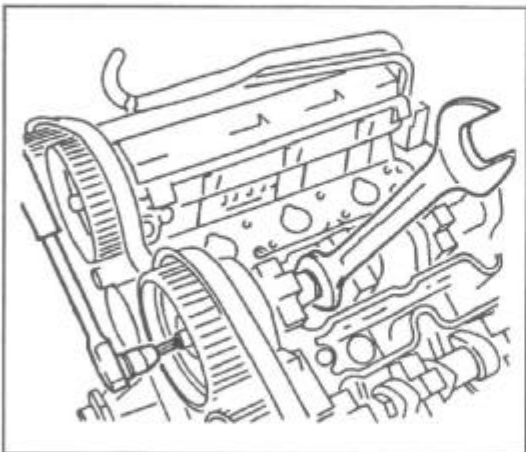

Install Toothed Belt

Attention:

Incorrect assembly may result in valve to piston, and intake to exhaust valve contact, resulting in damage. Always install a new toothed belt.

1. Loosen bolts on guide rollers (5) and (6) and nut on tension roller (7).

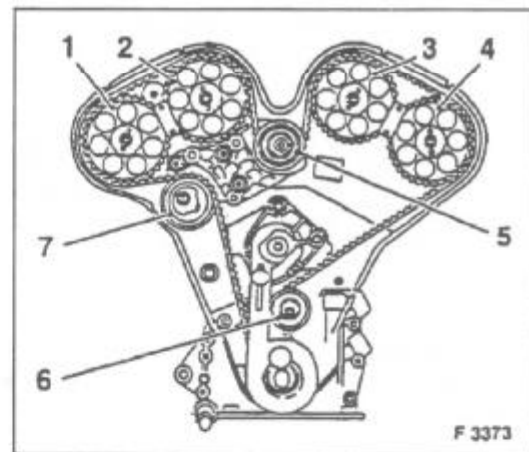

2. Align camshaft pulley marks (2) from left to right 1, 2, 3, 4, with notches (1) on belt rear cover.

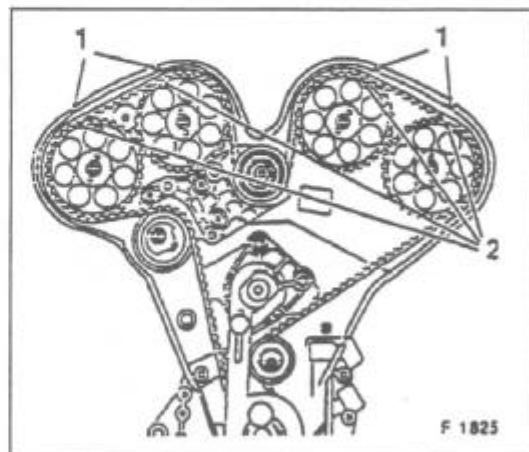

Vauxhall College - Multi-Valve V6 Engine

3. Lock camshaft pulleys 1 and 2 with KM-800-1 (red) and camshaft pulleys 3 and 4 with KM-800-2 (green) with "Top" marks upwards.

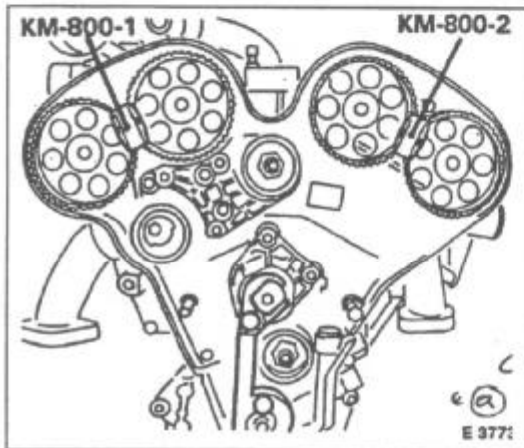

5. Note the following marks on the toothed belt:- The assistance marks (1) align with the camshaft pulley notches 1/2 and 3/4 and the rear cover notches. The running direction marks (2) point in engine rotational direction.. The double lines (3) align with the groove on the oil pump and notch on the drive pulley.

4. Install KM-800-10 to crankshaft toothed belt pulley. Turn crankshaft to TDC and lock tool to coolant pump (2 and 3)

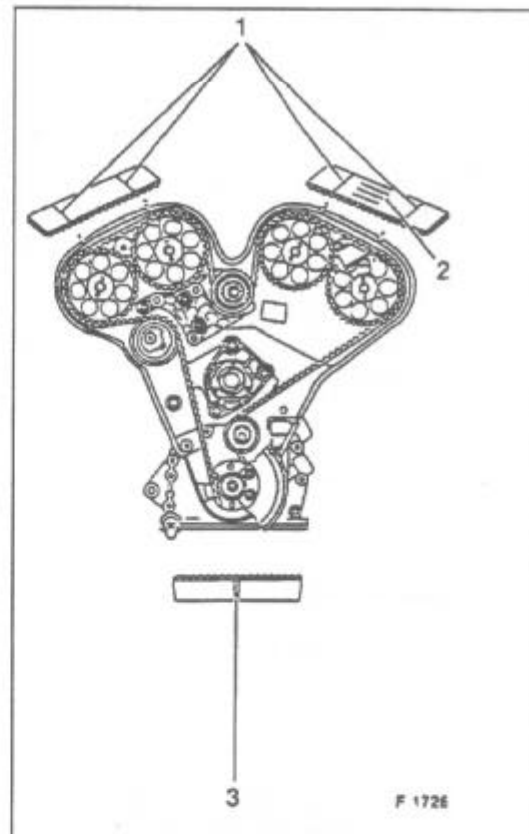
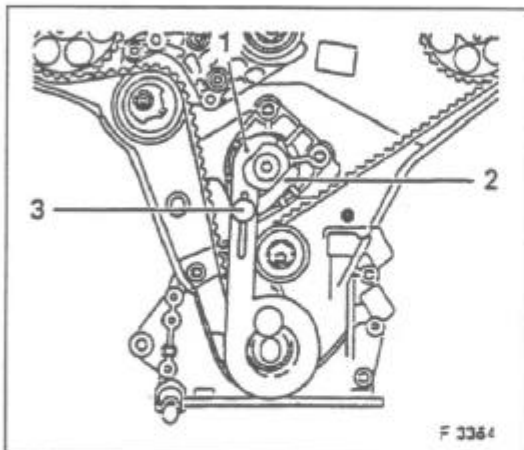

Vauxhall College - Multi-Valve V6 Engine

Installation

6. Install belt to crankshaft pulley, aligning double lines (1).
To prevent belt from slipping during subsequent operations wedge the belt between the oil pump and drive pulley using KM-800-30 (4).
(KM-800-30 not shown in illustration for clarity).

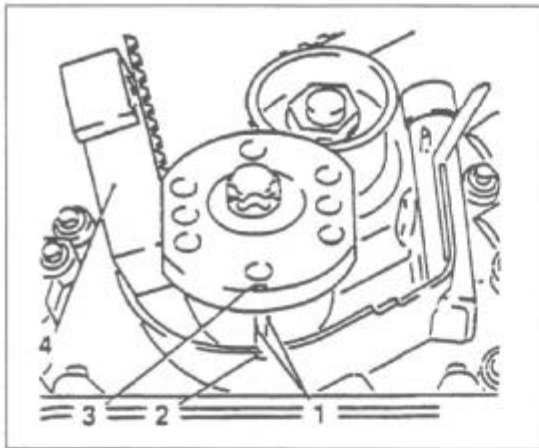

7. Position belt around lower guide roller (6) and camshaft pulleys (4) and (3) ensuring assistance marks are aligned. (Adjustment of guide roller 6 will adjust belt marks 3 and 4).
Position belt around upper guide roller (5) and camshaft pulleys (2) and (1), again ensuring assistance marks are aligned. (Adjustment of guide roller 5 will adjust marks 1 and 2).
Finally, position belt around tension roller (7).

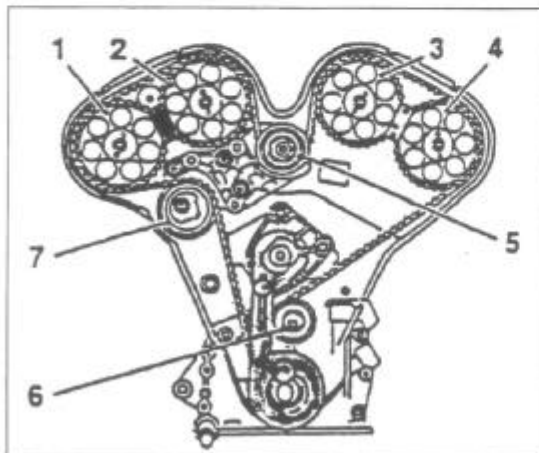

8. Always begin adjusting belt at lower guide roller (2).
Turn roller (2) anti-clockwise until belt is taut between roller (2) and camshaft pulley 4. Tighten roller (2) bolt to 40Nm.
Turn upper guide roller (1) anti-clockwise until belt is taut between camshaft pulleys 2 and 3. Tighten roller (1) bolt to 40Nm.

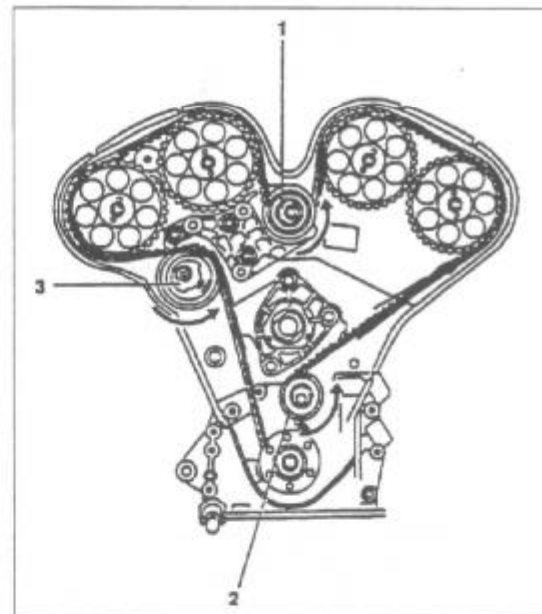

Note: Due to changes in the belt tensioner and associated components from engine No. 144300, a new procedure for belt fitting and adjustment must be followed.
(See section 6 page 17 for details)

Vauxhall College - Multi-Valve V6 Engine

9. Tension belt with tension roller by turning anti-clockwise with 5mm wrench until a gap of 5mm as shown below is reached. Tighten nut to 20Nm.

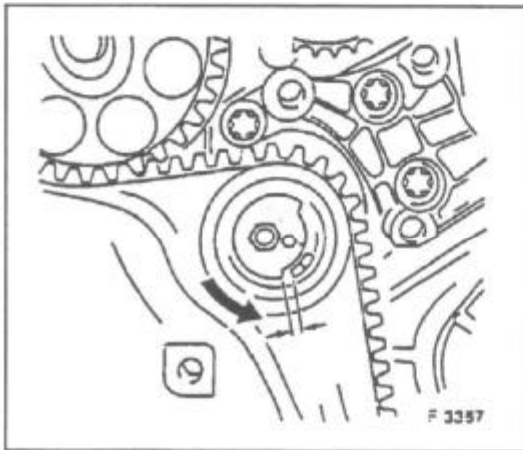

10. Remove all tools and rotate crankshaft through 2 revolutions, returning to TDC using locking tool KM-800-10.

(Note:- The line markings on the belt will no longer align.)

Check adjustment of camshaft pulleys 3 and 4 with gauge KM-800-20 (1).

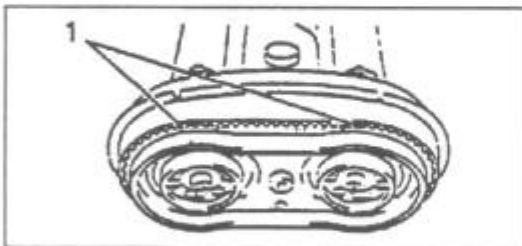

11. If the marking on the pulley are located before the markings on the gauge, loosen guide roller 2 and turn anti-clockwise until marks on pulleys align with gauge. Tighten pulley bolt (2) to 40Nm.

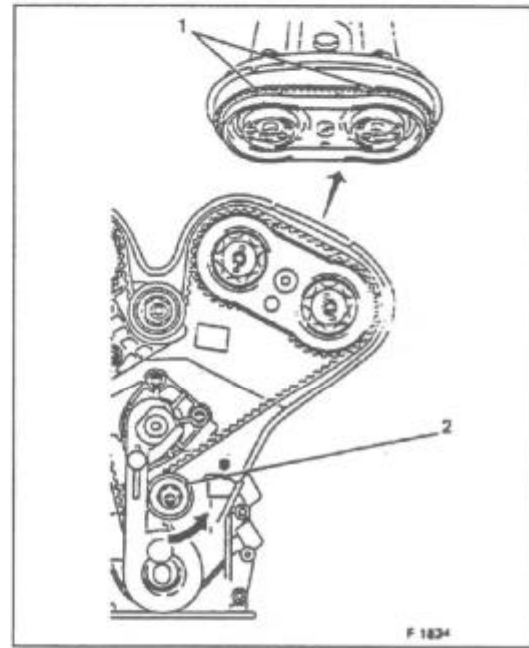

12. Remove all tools, rotate crankshaft through 2 revolutions returning to TDC with KM-800-10. Check alignment of camshaft pulley marks with KM-800-20 and repeat adjustment if necessary until marks align exactly.

Vauxhall College - Multi-Valve V6 Engine

13. If the markings on the pulleys 3 and 4 are after the marks on the gauge, loosen guide roller (2) bolt and turn roller clockwise. The pulleys 3 and 4 will not move at first.
Tighten roller bolt to 40Nm.
Remove all tools and rotate crankshaft clockwise 2 turns returning to TDC with KM-800-10. Check alignment of camshaft pulley marks with KM-800-20 and repeat adjustment if necessary until marks align exactly.

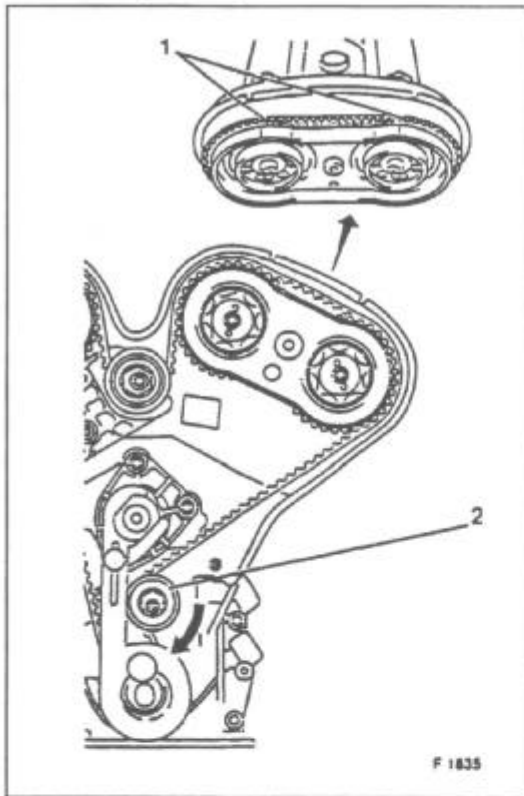

14. Check adjustment of camshaft pulleys 1 and 2 with gauge KM-800-20 when camshaft pulleys 3 and 4 are correct.

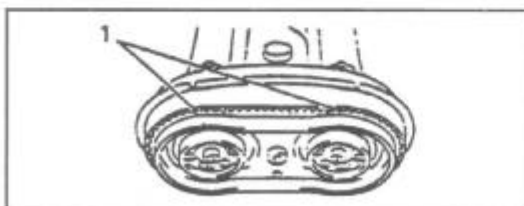

15. If the marking on pulleys 1 and 2 are before the marking on the gauge, loosen guide roller (2) and turn roller anti-clockwise until markings on pulleys align with gauge. Tighten roller bolt to 40Nm.
Remove all tools and rotate crankshaft clockwise 2 turns returning to TDC with KM-800-10. Check alignment of pulley marks with KM-800-20 and repeat if necessary until marks align exactly.

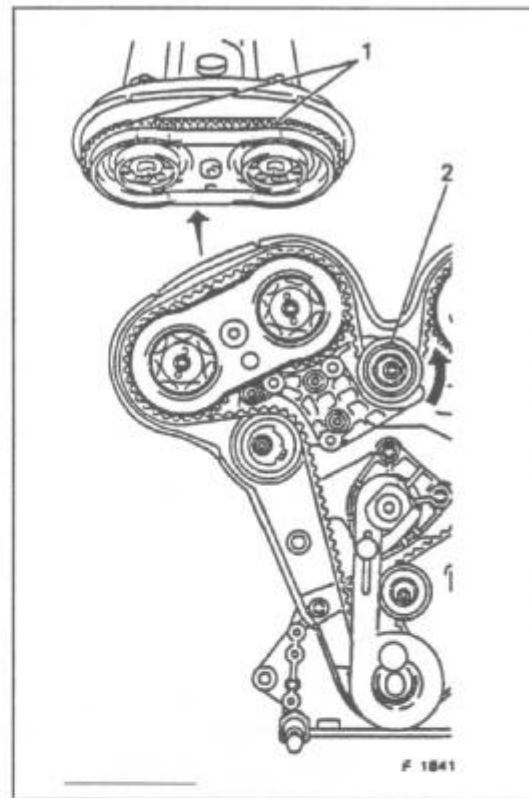

Vauxhall College - Multi-Valve V6 Engine

16. If the markings on the pulleys 1 and 2 are located after the marks on the gauge, loosen guide roller (2) bolt and turn roller clockwise. The pulleys 1 and 2 will not move at first.

Tighten roller bolt to 40Nm. Remove all tools and rotate crankshaft clockwise 2 turns returning to TDC with KM-800-10. Check alignment of camshaft pulley marks with KM-800-20 and repeat adjustment if necessary until marks align exactly.

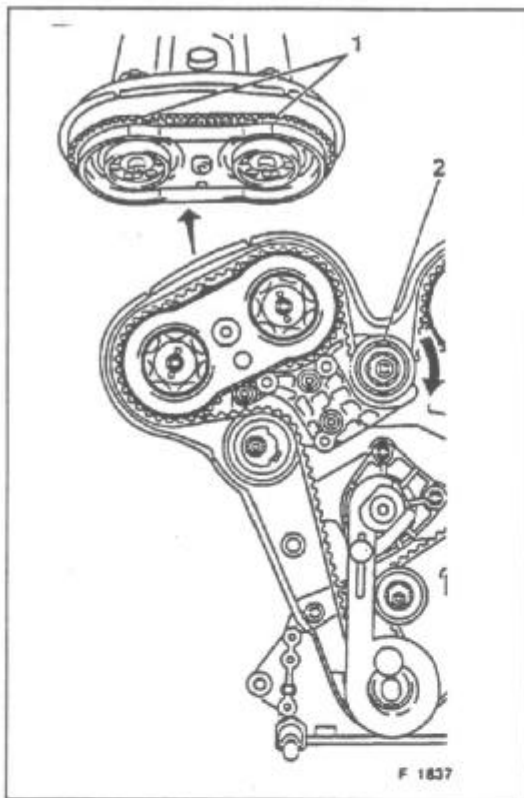

17. Loosen toothed belt tension roller nut. Tension roller with 5mm wrench anti-clockwise until gap of 5mm as shown, is reached. Tighten nut to 20 Nm.

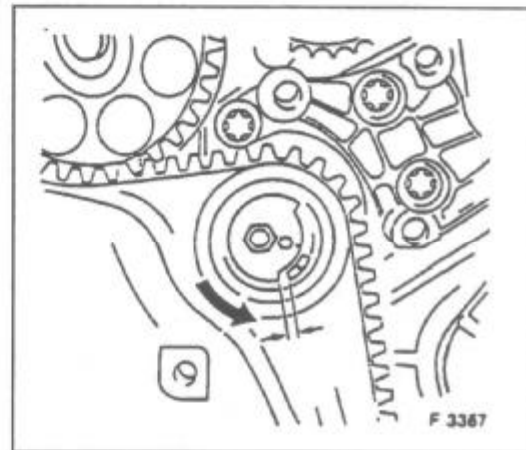

18. Remove locking tool and rotate crankshaft clockwise 2 turns returning to TDC with KM-800-10. Loosen tension roller nut and turn roller clockwise until marking (1) is 2 to 4mm above marking (2). Tighten nut to 20Nm.

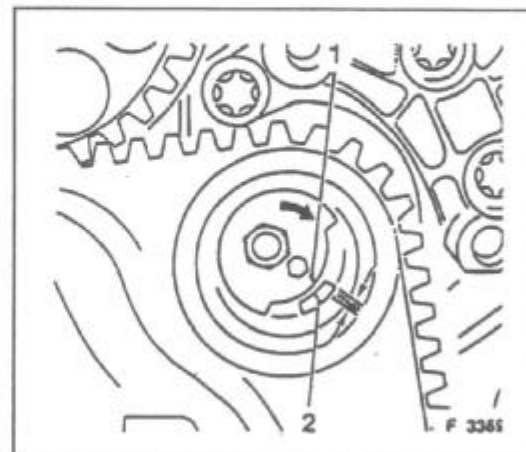

Vauxhall College - Multi-Valve V6 Engine

19. Remove locking tool and rotate crankshaft through 2 revolutions returning to TDC with KM-800-10. Check adjustment of the toothed belt tension roller. Marking (1) must now lie at or up to 2mm above marking 2. Under no circumstances should marking (1) lie below marking 2. If necessary repeat procedures 16-19. Remove locking tool KM-800-10.

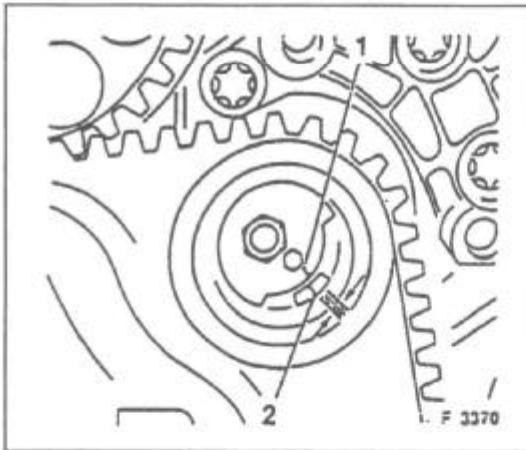

Important:

After any adjustment the crankshaft must be turned through 2 revolutions, returning to T.D.C. mark and all timing marks checked for correct alignment and tensioner roller checked for correct tension.

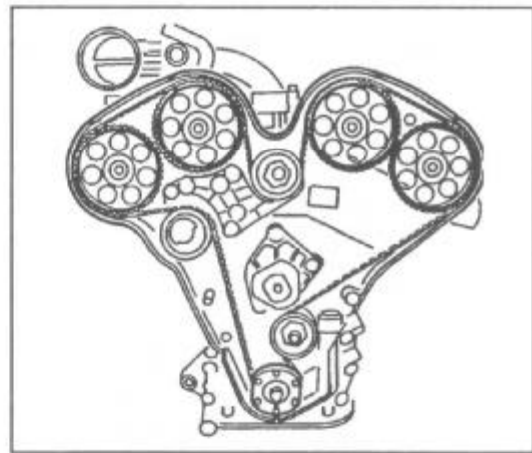

ENGINE NO change.

Vauxhall College - Multi-Valve V6 Engine

Installation of New Type Belt

On engines numbered from 144300 onwards, a new belt and tensioner are fitted, which require a new method of installation and adjustment. The new belt is thicker, and can be recognised by a coloured line around the edge. The tensioner is identified by the addition of a raised edge on the outer side of the tensioner pulley, so a different method of belt installation is necessary, as follows.

Fit **New** belt to pulleys (1) and (2), then feed belt around tensioner (7). Guide belt around crankshaft pulley and pull through any slack. At this point the double mark on the belt will **NOT** line up with the pulley, but will be one tooth to the right. Insert KM-800-30 to hold the belt in place, then position the belt around the lower idler (6).

Feed upper part of belt around upper idler (5), then fit belt to pulleys (3) and (4).

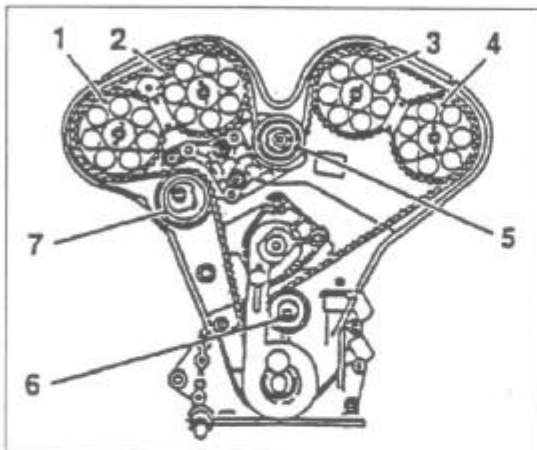

The pass the belt back under the crankshaft pulley to correctly align the double mark with the pulley.

Next, adjust the lower idler then the upper idler in the normal manner to eliminate any slack in the belt.

Using a 5mm allen key, turn the automatic adjuster anti-clockwise as far as it will go, then slacken until the mark on the tensioner is 1mm above the floating timing block. Tighten nut with 13mm spanner.

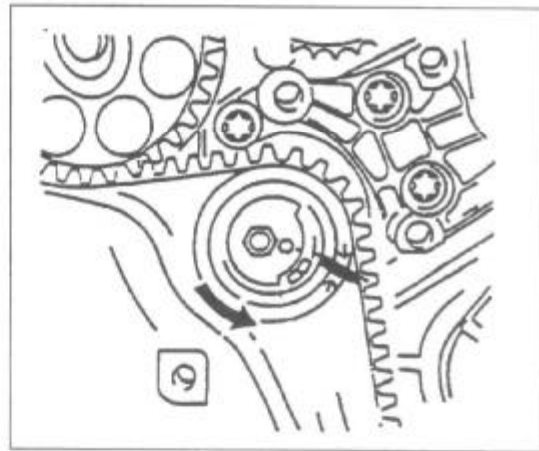

Remove all tools, rotate engine two complete turns, then refit KM-800-10. Adjust belt in the usual way, then finally adjust the tensioner so that tensioner setting mark falls within the top quarter of the floating timing block, ie 1mm below the edge of the block.

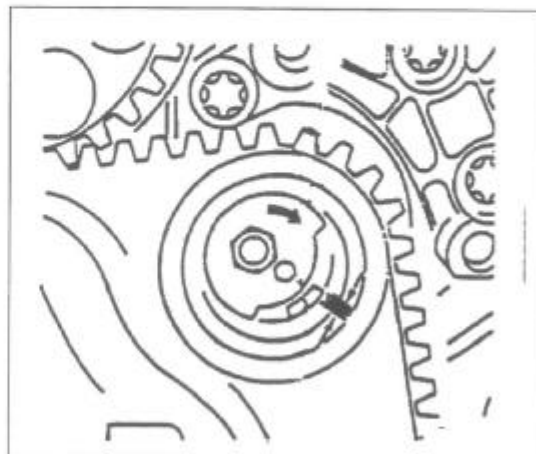

Vauxhall College - Multi-Valve V6 Engine

Install Valve Covers

Install left hand and right hand valve covers (noting marks) ensure all 'O' rings are correctly installed.

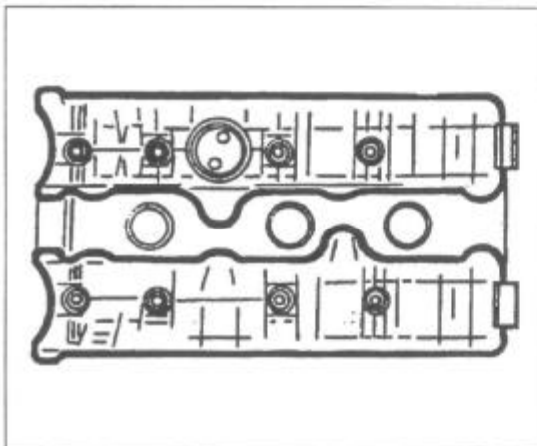

Install Intake Manifold Centre Part and Injector Valves

Insert injector valves and fuel lines.

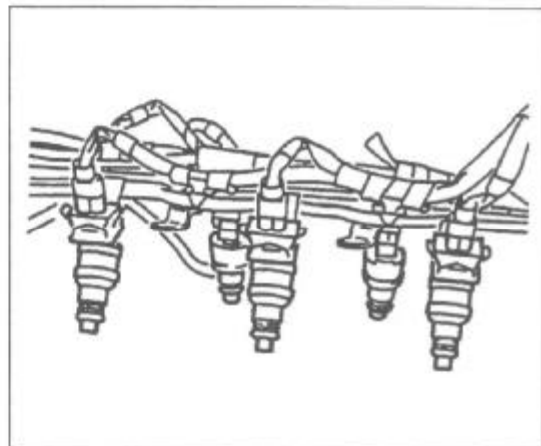

Install intake manifold centre part (fuel pressure regulator to front of engine).

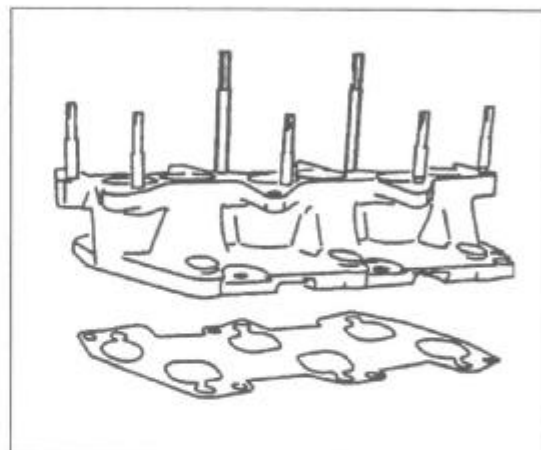

Install injector cable plugs.
Note correct numbers.

Vauxhall College - Multi-Valve V6 Engine

Install Spark Plugs/Ignition Cables

Install ignition coil. Using KM-194-B install spark plugs and ignition cables.

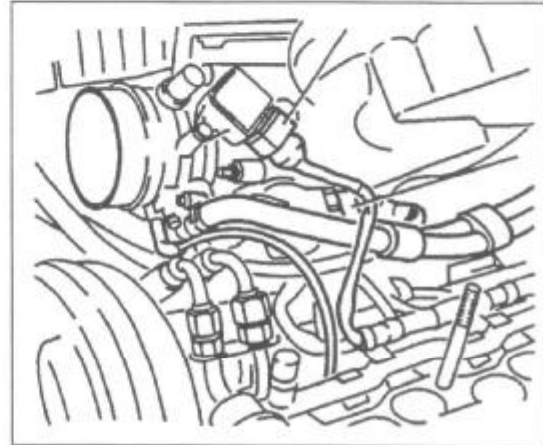
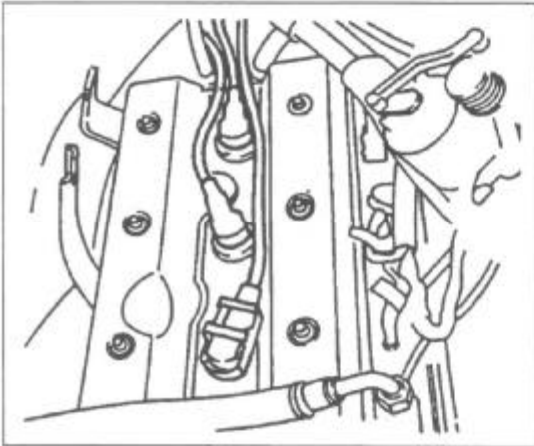

Install Clutch/Flywheel or Flexplate

Install flywheel or flexplate assembly and using holding tool KM-652 tighten holding bolts to a torque of 65 Nm +30°+15°.

Install clutch assembly.

Install Intake Manifold Upper Part

Connect idle air speed adjuster cable, ETC cable and throttle potentiometer.

Install intake manifold upper part (ensuring no hoses are trapped).

Connect all hose, vacuum and coolant connections.

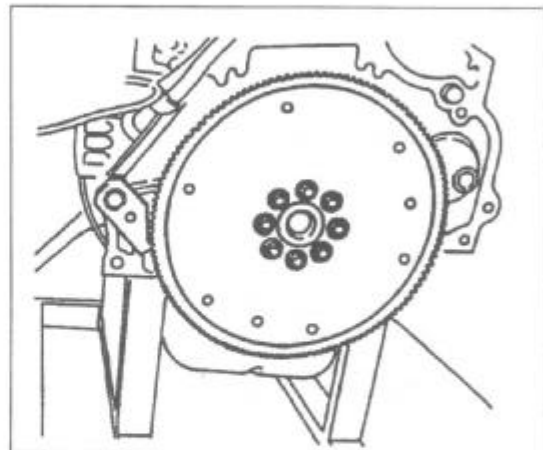
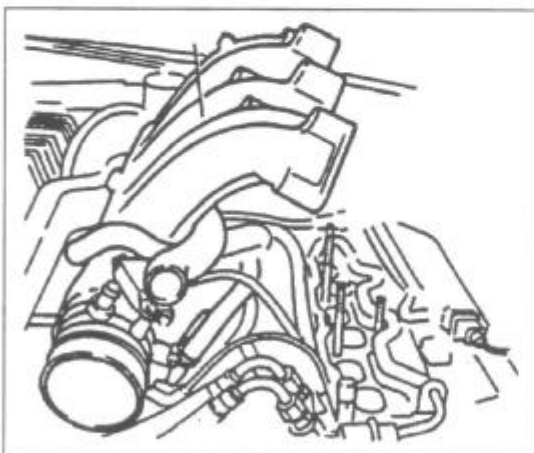

Vauxhall College - Multi-Valve V6 Engine

Install Front Tooth Belt Cover

Install front tooth belt cover.

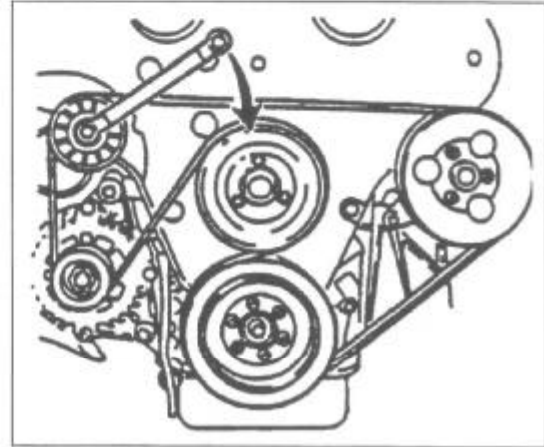
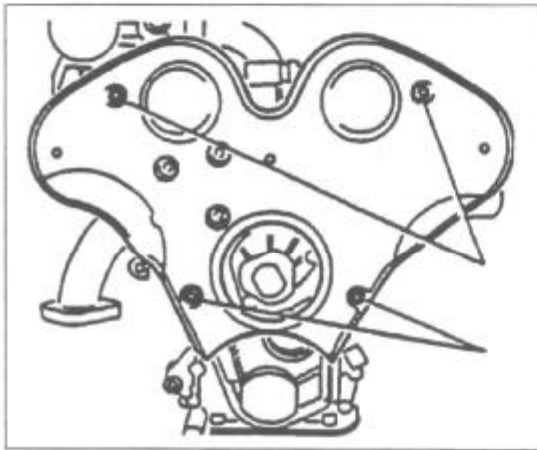

Tighten 3 screws of power steering pump pulley.

Install oil filter, starter and 2 knock sensors.

Install Poly 'v' Belt

Install water pump pulley. Install power steering pump and pulley.

Install crankshaft pulley (holes are offset for correct installation).

Install tensioner and support for poly 'v' belt.

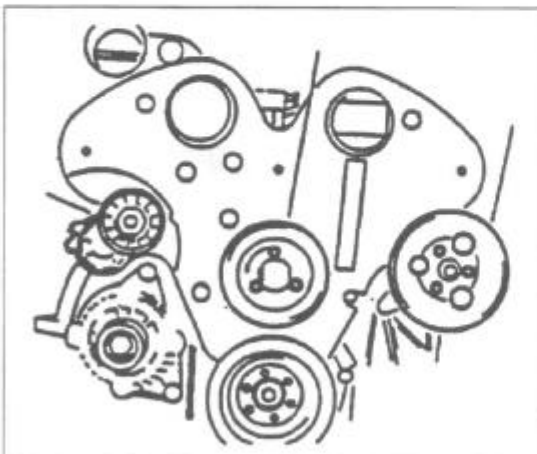

Install poly 'v' belt.

Vauxhall College - Multi-Valve V6 Engine

Section 7

Engine Specifications

Vauxhall College - Multi-Valve V6 Engine

Torque Values for C25XE V6 Engine

Screw Connection	Torque (Nm)	Angular Torque
Crankshaft main bearing cap and bridge to cylinder block (M10)	50...	+60°+15°
Crankshaft bridge to cylinder block (M8)	20	
Con-rod cap to con rod (M9)	35...	+45°+15°
Oil pump cover to oil pump (M6)	8	
Oil pump to cylinder block (M6)	6	
Suction pipe to oil pump (M6)	8	
Oil pan to cylinder block (M8)	15	
Knock sensor to cylinder block (M8)	20	
Crankshaft tooth belt gear to crankshaft (M16)	250...	+45°+15°
Oil filter to engine block (M18)	15	
Flywheel to crankshaft (M10)	65...	+35°+15°
Cylinder head to cylinder block (M11)	25...	+90°+90°+90°+15°
Camshaft bearing caps to cylinder head (M6)	8	
Cylinder head cover to camshaft bearing caps (M6)	8	
Camshaft gears to camshafts (M10)	50...	+60°+15°
Spark plugs (M14)	25	
Exhaust manifolds to cylinder heads (M8)	20	
Inlet manifold (lower) to cylinder head (M8)	20	
Injection unit to inlet manifold lower (M8)	20	
Inlet manifold (upper) to injection housing (M8)	20	
Note: All bolts tightened by angular torque must be renewed		

Vauxhall College - Multi-Valve V6 Engine

C25XE Bearing Shells

No colour	090354664	(Bearing STD size Conrod)
Blue	090354666	(Bearing U/S Conrod)
Brown	090354669	(Bearing STD Crankshaft) No. 1 Upper and Lower
Green	090354670	(Bearing STD Crankshaft) No. 1 Upper and Lower
Brown-Blue	090354671	(Bearing U/S Crankshaft) No. 1 Upper and Lower (0.25 mm)
Green-Blue	090354672	(Bearing U/S Crankshaft) No. 1 Upper and Lower (0.25 mm)
Brown	090354673	(Bearing Upper Crankshaft) No. 2 and 3
Green	090354674	(Bearing Upper Crankshaft) No. 2 and 3
Brown-Blue	090354675	(Bearing Upper U/S Crankshaft) No. 2 and 3 (0.25 mm)
Green-Blue	090354676	(Bearing Upper U/S Crankshaft) No. 2 and 3 (0.25 mm)
Brown	090354677	(Bearing Lower Crankshaft) No. 2 and 3
Green	090354678	(Bearing Lower Crankshaft) No. 2 and 3
Brown-Blue	090354679	(Bearing Lower U/S Crankshaft) No. 2 and 3 (0.25 mm)
Green-Blue	090354680	(Bearing Lower U/S Crankshaft) No. 2 and 3 (0.25 mm)
Brown	0904100685	(GDE BRG S/S Crankshaft)
Green	090410686	(GDE BRG S/S Crankshaft)
Brown-Blue	090412007	(GDE BRG U/S Crankshaft) (0.25 mm)
Green-Blue	090412008	(GDE BRG U/S Crankshaft) (0.25 mm)

Vauxhall College - Multi-Valve V6 Engine

Section 8

Wiring Diagram

Vauxhall College - Multi-Valve V6 Engine

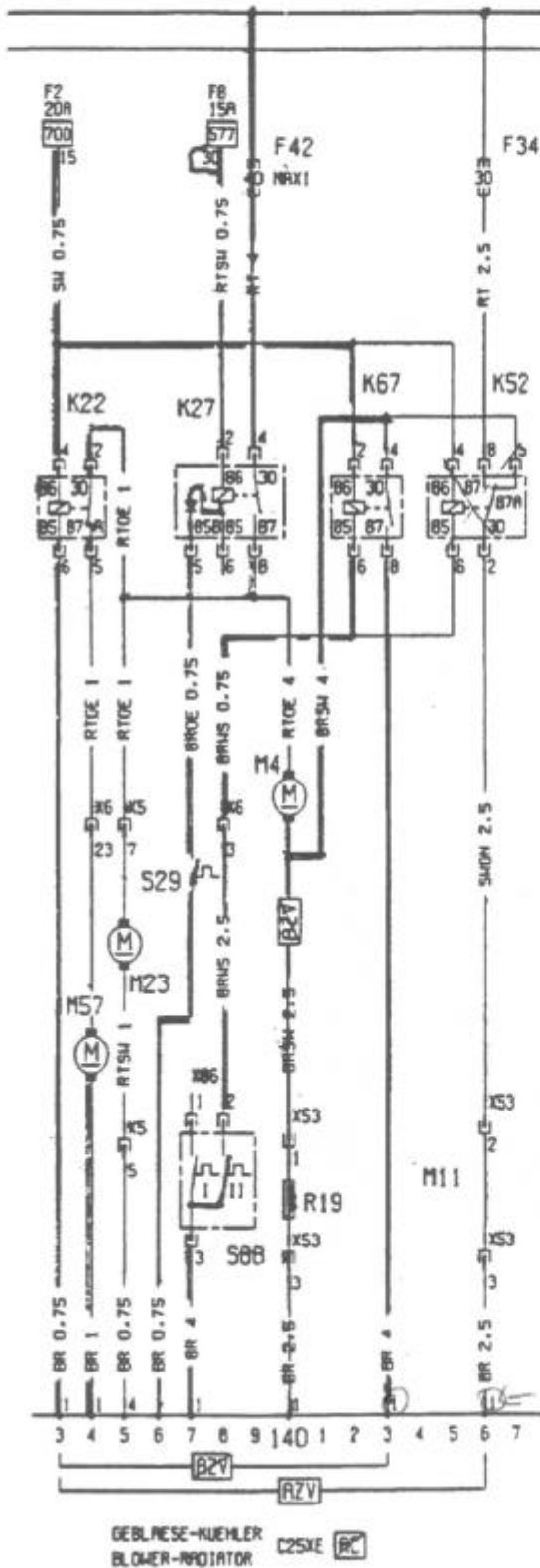

- F34 FUSE-BLOWER, RADIATOR
- F42 FUSE-BLOWER, RADIATOR (MARK I)
- K20 IGNITION MODUL-IGNITION COIL
- K22 RELAY-PUMP, COOLANT
- K27 RELAY-BLOWER, RADIATOR
- K52 RELAY-BLOWER, RADIATOR
- K67 RELAY-BLOWER, RADIATOR
- K84 CONTROL UNIT-EZ PLUS
- L1 IGNITION COIL *L2 Dis*
- M4 MOTOR-BLOWER, RADIATOR
- M11 MOTOR-BLOWER, RADIATOR
- M23 MOTOR-BLOWER, ALTERNATOR
- M57 PUMP-COOLANT
- P23 SENSOR-ABSOLUTE PRESSURE, INTAKE MANIFOLD
- P24 TEMPERATURE SENSOR-OIL, ENGINE
- R19 PRERESISTOR-BLOWER, RADIATOR
- S29 SWITCH-TEMPERATURE, COOLANT
- S88 SWITCH-TEMPERATURE, COOLANT, 2 STAGES
- Y10 IGNITION DISTRIBUTOR-HALL SENSOR
- Y25 SOLENOID VALVE-REVOLUTION ACCELERATION
- X5 INSTRUMENT PANEL & ENGINE 14P
- X6 INSTRUMENT PANEL & BODY 51P
- X13 DIAGNOSTIC LINK 10P
- X15 OCTANE NUMBER 3P
- X53 INSTR. PANEL & BLOWER, RADIATOR/PRESISTOR 3
- X86 BODY & SWITCH-TEMP. COOLANT 3P

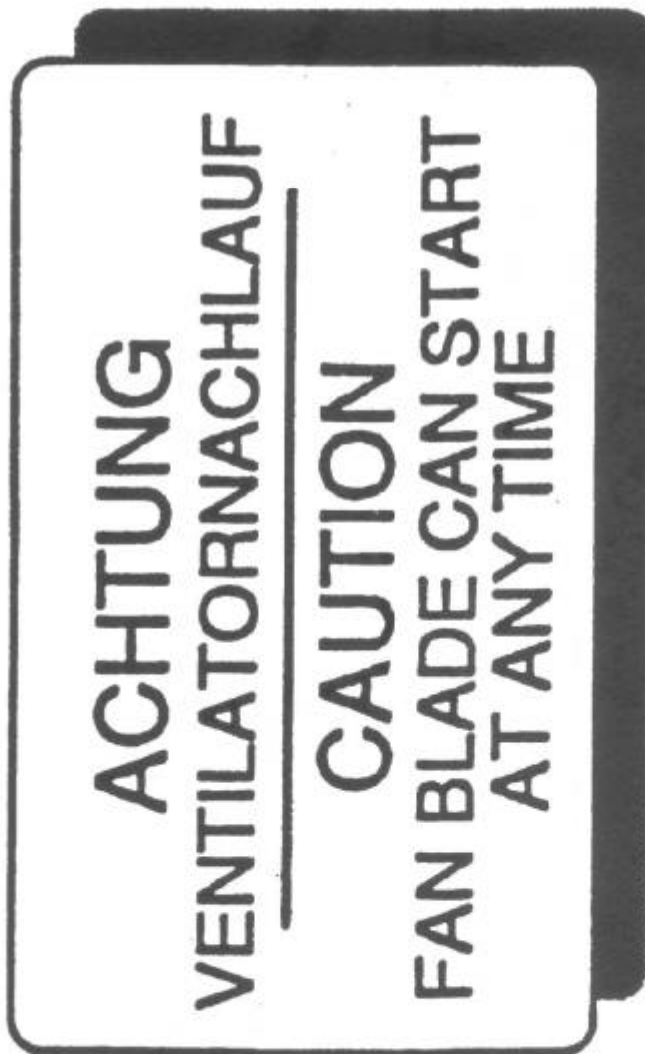

E 0543

Vauxhall College - Multi-Valve V6 Engine

Section 9

**X 25 XE & X 30 XE Engines
Longitudinal Installation
Omega B**

Vauxhall College - Multi-Valve V6 Engine

X 25 XE and X 30 XE V6 Engine (Longitudinal)

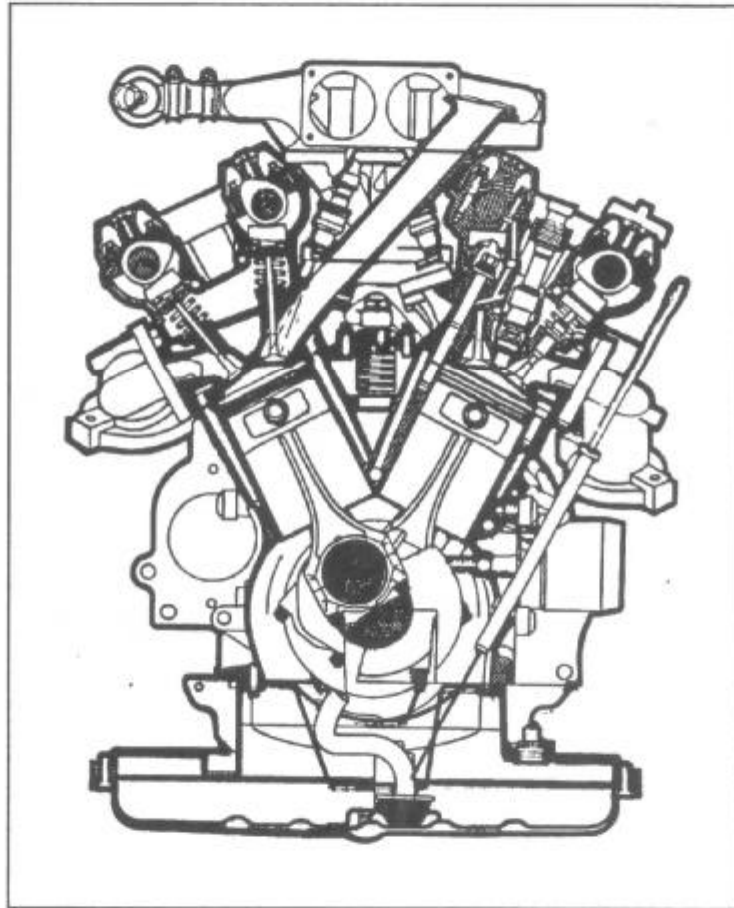

Based on the C 25 XE, the X 25 XE and X30 XE engines feature the following major differences:-

- Oil pan aluminium support providing increased engine and transmission rigidity
- New intake design featuring multi-ram system to improve torque characteristics
- E.G.R. (Exhaust Gas Recirculation) system and secondary air system
- Conforms to EC 96 Emission Limits
- Increased Bore and Stroke (X 30 XE)
- Fully floating piston pins (X 30 XE only)
- Sodium filled Exhaust Valves (X 30 XE only)

Vauxhall College - Multi-Valve V6 Engine

Spark Plug Renewal

Remove spark plug leads with supplied special tool

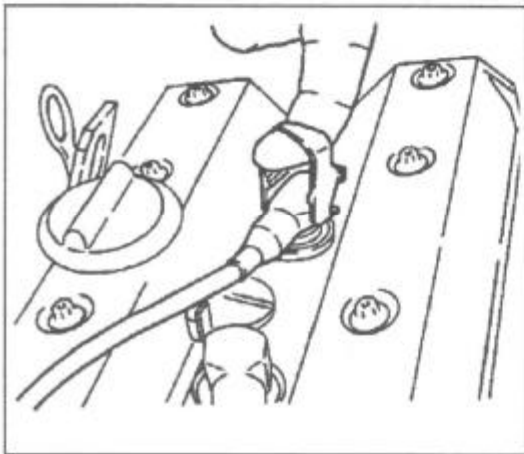

To facilitate the removal of No. 1 spark plug, remove accelerator cable from bracket on engine. Loosen rear cable bracket screw and remove front screw (1).

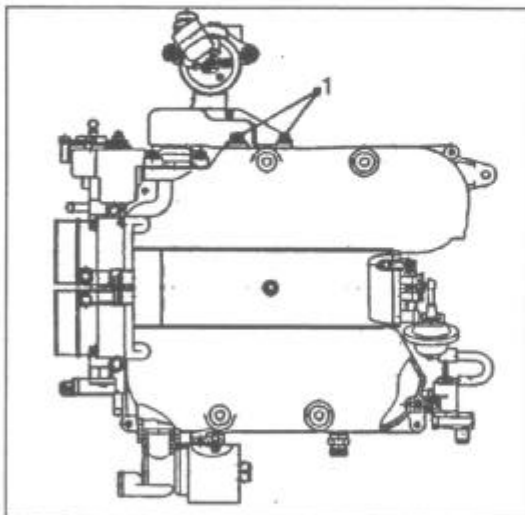

Remove and install sparking plugs **only** with special wrench KM 194B.



Tighten sparking plugs to 25 Nm.

Install plug leads and refit accelerator cable bracket. Refit accelerator cable.

Vauxhall College - Multi-Valve V6 Engine

Basic strip down and rebuild is identical to Sections 4, 5 and 6 with the following changes.

Remove Intake System

Remove corrugated pipe (1) and support stay (2) from E.G.R. valve (3).

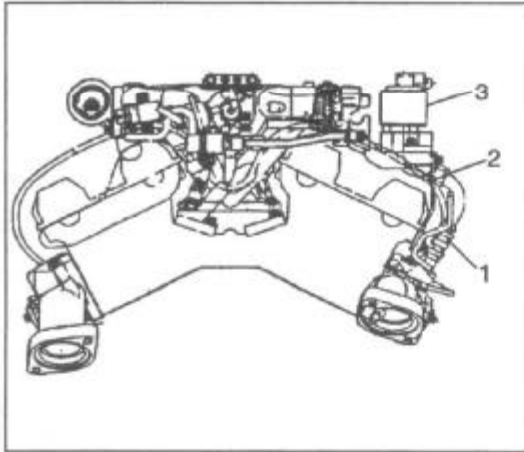

Remove the 4 hoses from the manifold top cover (1).

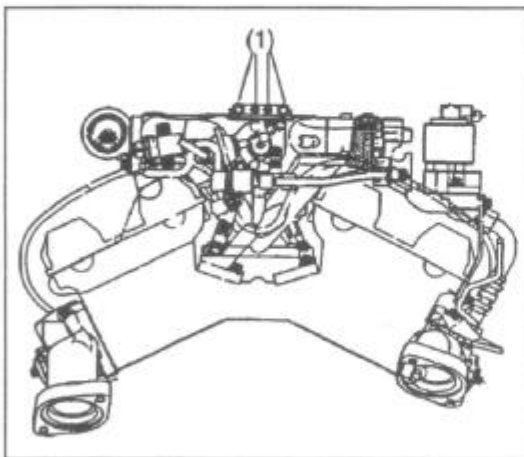

Remove coolant hose from throttle body (1).

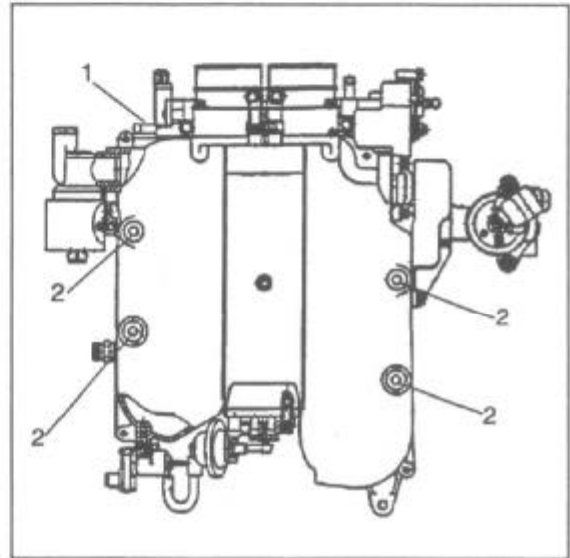

Remove hose from fuel pressure regulator.

Remove the 4 closure plugs (2) from top of intake manifold.

Remove the four screws securing manifold to fuel injection unit.

Vauxhall College - Multi-Valve V6 Engine

Remove Fuel System

If required, remove fuel injection wiring harness (1) and injection valves (2), with fuel distribution tube (3).

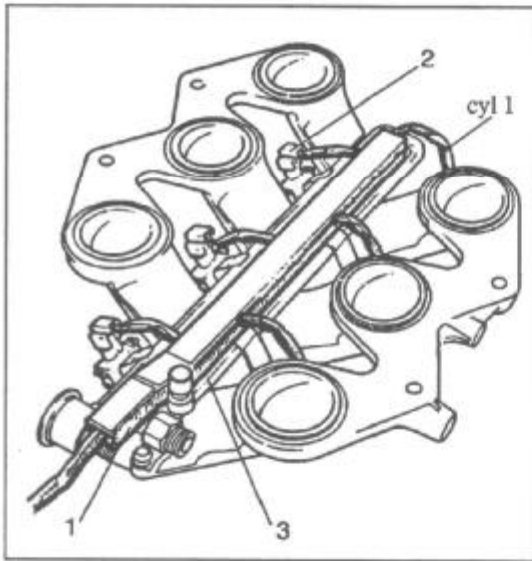

Remove 6 torx screws from fuel injection unit (1) and tilt unit whilst removing.

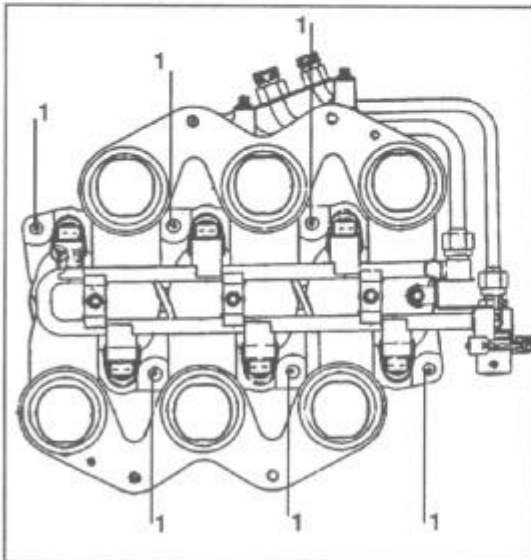

Lower Intake Manifold - remove

Remove 12 screws (1) from plastic lower manifold, remove manifold.

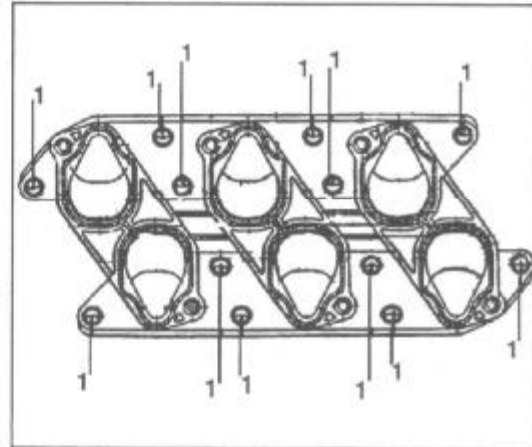

Clean and Inspect

Renew all 'O' rings and seals, clean and inspect all parts before reassembly.

Vauxhall College - Multi-Valve V6 Engine

Camshafts

Different camshafts are fitted depending on the engine type.

The camshafts can be identified by a colour marking (1) and a code letter (2).

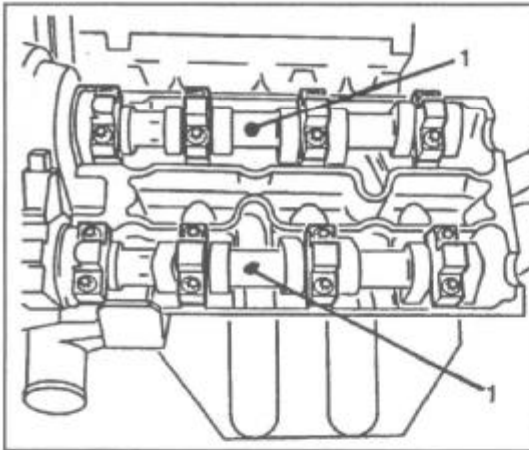

The camshafts for the C 25 XE engine are identical for intake and exhaust.

The camshafts for the X 25 XE and the X 30 XE are different for the intake and exhaust.

When installing camshafts in V6 engines use the following table for the correct installation.

ENGINE	INTAKE	EXHAUST
C 25 XE	GREEN (A)	GREEN (A)
X 25 XE	BROWN (F)	WHITE (E)
X 30 XE	BLUE (G)	GREEN (A)

Vauxhall College - Multi-Valve V6 Engine

Oil Pan and Oil Pan Support - Remove

Remove retaining clip from oil level sensor connector in oil pan support (1).

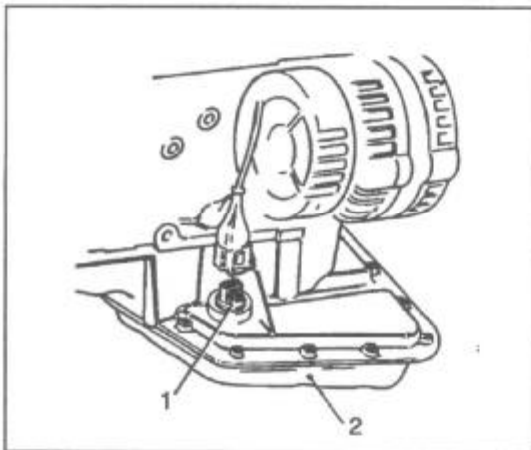

Remove torx screws from oil pan and remove oil pan (2).

Note: Remove oil level sensor connector from oil pan support whilst removing oil pan - do not strain cable (1).

Remove 17 torx screws (1) from oil pan support and remove support.

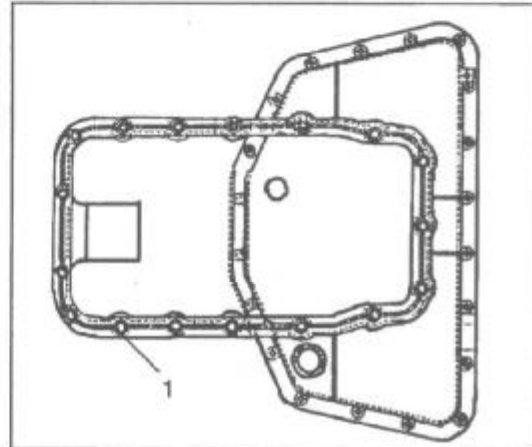

Clean removed components and inspect all parts.

Renew all seals before re-assembly.

Remove sealer from block face and clean.

Vauxhall College - Multi-Valve V6 Engine

Piston and Connecting Rod 3.0 Litre Engine Only

Piston and connecting rod removal - 3.0 litre engine, is similar to the C 25 XE engine - see Section 4.

The piston and connecting rod for the 3.0 litre engine has a fully floating piston pin retained by 2 circlips (1) in the piston.

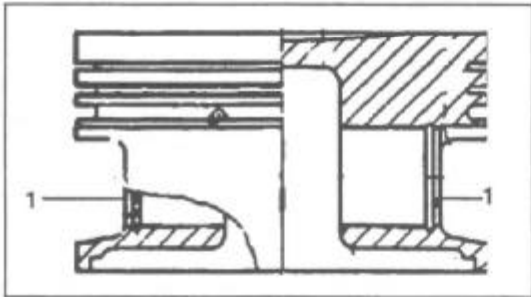

These circlips must never be re-used.

The connecting rod is equipped with a press fitted bush which is finished to the dimension shown (1)

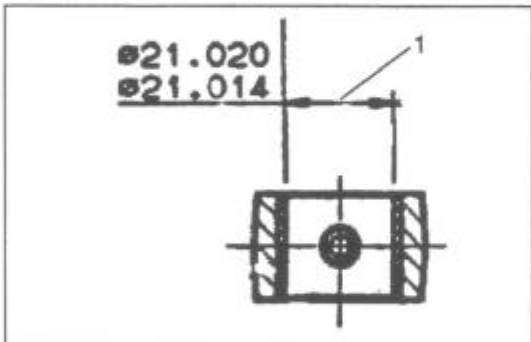

The connecting rods must all be of the same weight group in engine.

Connecting rods are therefore only supplied in sets of 6.

The 3.0 litre engine pistons are marked with a size on the crown (1) for selective fit in the bore.

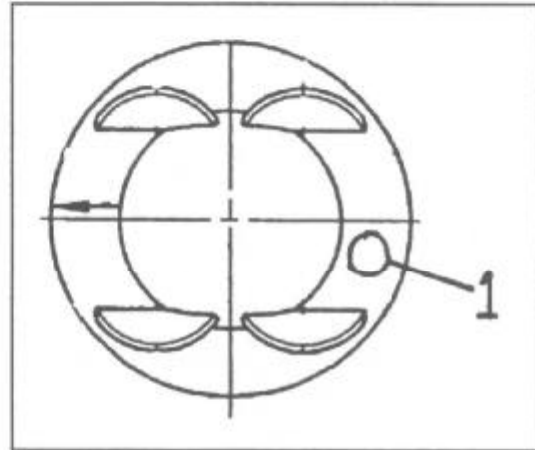

The cylinder bore sizes are marked on the block top face (see section 5).

Refer to the following table to determine selective fit sizes.

SIZE	MARKING No.	BORE SIZE ABOVE-TO	PISTON SIZE ABOVE-TO
1	8	3 85.975 - 85.985	3 85.940 - 85.950
	99	85.985 - 85.995	85.950 - 85.960
	00	85.995 - 86.005	85.960 - 85.970
	01	86.005 - 86.015	85.970 - 85.980
2	02	86.015 - 86.025	85.980 - 85.990
	7 + 0.5	86.465 - 86.475	86.430 - 86.440
OVERSIZE +0.5	8 + 0.5	86.475 - 86.485	86.440 - 86.450
	9 + 0.5	86.485 - 86.495	86.450 - 86.460
	0 + 0.5	86.495 - 86.505	86.460 - 86.470

PistonRings

Refer to Section 5

Vauxhall College - Multi-Valve V6 Engine

Install Oil Pan and Oil Support Pan

Apply Silicon sealer 90001851 to oil pump and rear main bearing joint areas as shown (1).

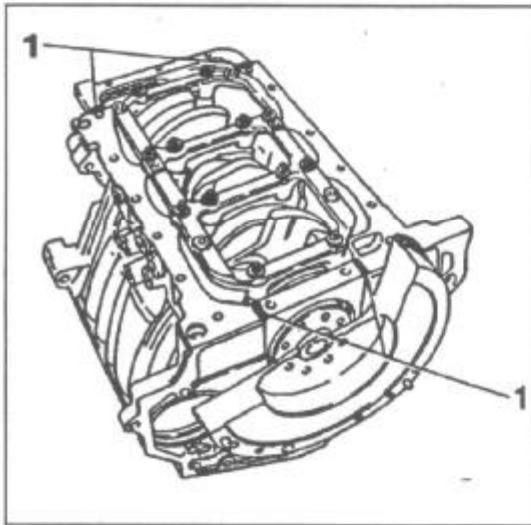

Install rubber seal to oil pan support using tab on seal and recess in support as reference points.

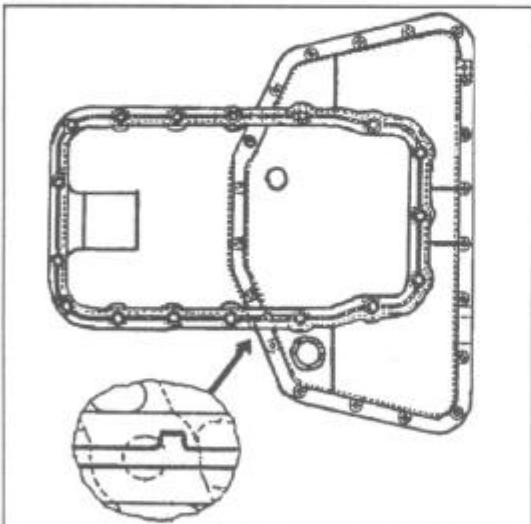

Install oil pan support and torx screws to block. Tighten bolts to 15 Nm from the centre to the outside.

Position oil pan seal on oil pan (seal will only fit in one position).

Fit oil level sensor connector to oil pan support **before** installing oil pan completely (1)

Install oil pan, tighten screws to 8 Nm (2). Install retaining clip to oil level sensor connector (1).

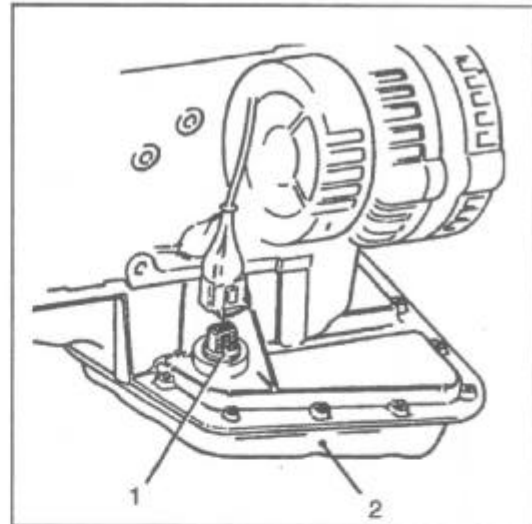

Vauxhall College - Multi-Valve V6 Engine

Install Fuel and Intake System

Install lower manifold to cylinder heads with new seals. Tighten screws in order shown to 20 Nm.

Install fuel injection unit to lower manifold using new seals, with fuel pressure regulator (if fitted) to rear of engine. Install screws and tighten in order shown to 20 Nm.

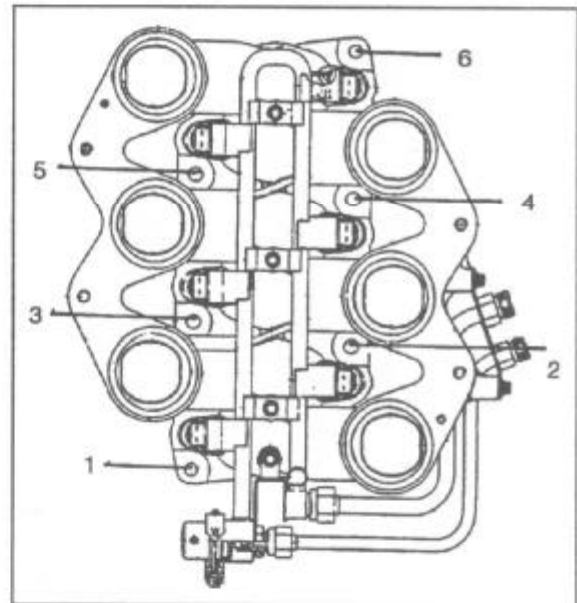
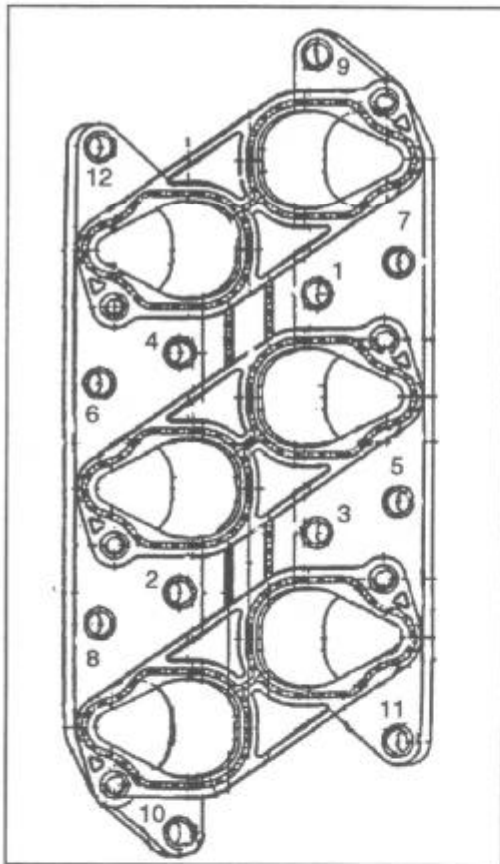

Note: Lower manifold will fit either way round.

Vauxhall College - Multi-Valve V6 Engine

If necessary fit fuel injection valves (2), and distribution tube (3) to fuel injection unit with regulator to rear of engine using new seals. Tighten screws to 8 Nm.

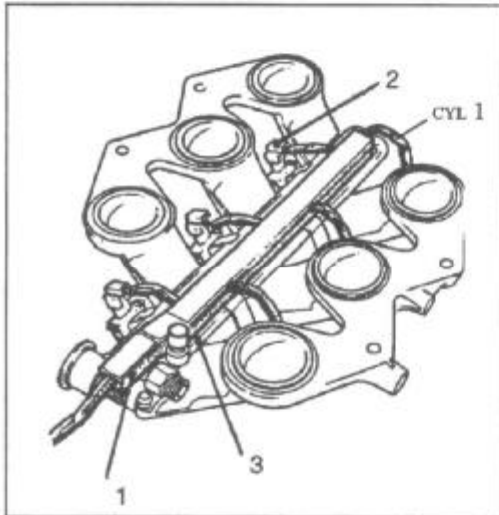

Fit injection harness to distribution tube and connect injector plugs to their correct injector numbers (2).

Carefully install upper manifold ensuring dowels are engaged. Install torx screws (2) and tighten to 20 Nm. Install closure plugs.

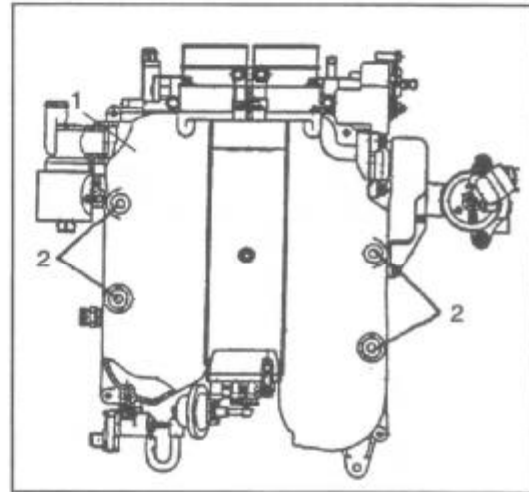

Install coolant hose to throttle body (1) and hose to fuel pressure regulator.

Vauxhall College - Multi-Valve V6 Engine

Install the 4 hoses to the manifold top cover.

Note fuel ventilation valve connection (1), and small crankcase ventilation hose (2)

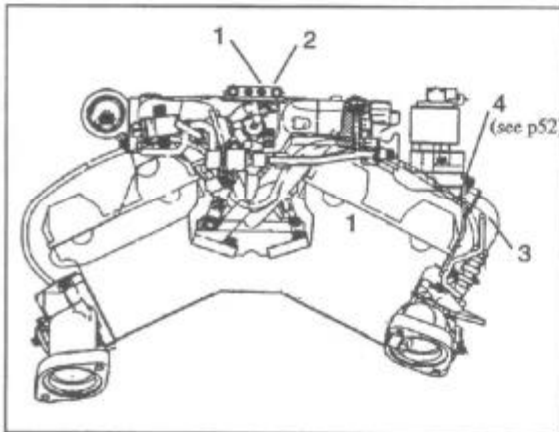

Install corrugated pipe to E.G.R. valve and exhaust manifold (3) and support bracket (4).

Vauxhall College - Multi-Valve V6 Engine

Section 10

X 25 XE

Transverse Installation

Vectra B

Vauxhall College - Multi-Valve V6 Engine

X25XE Engine (Transverse)

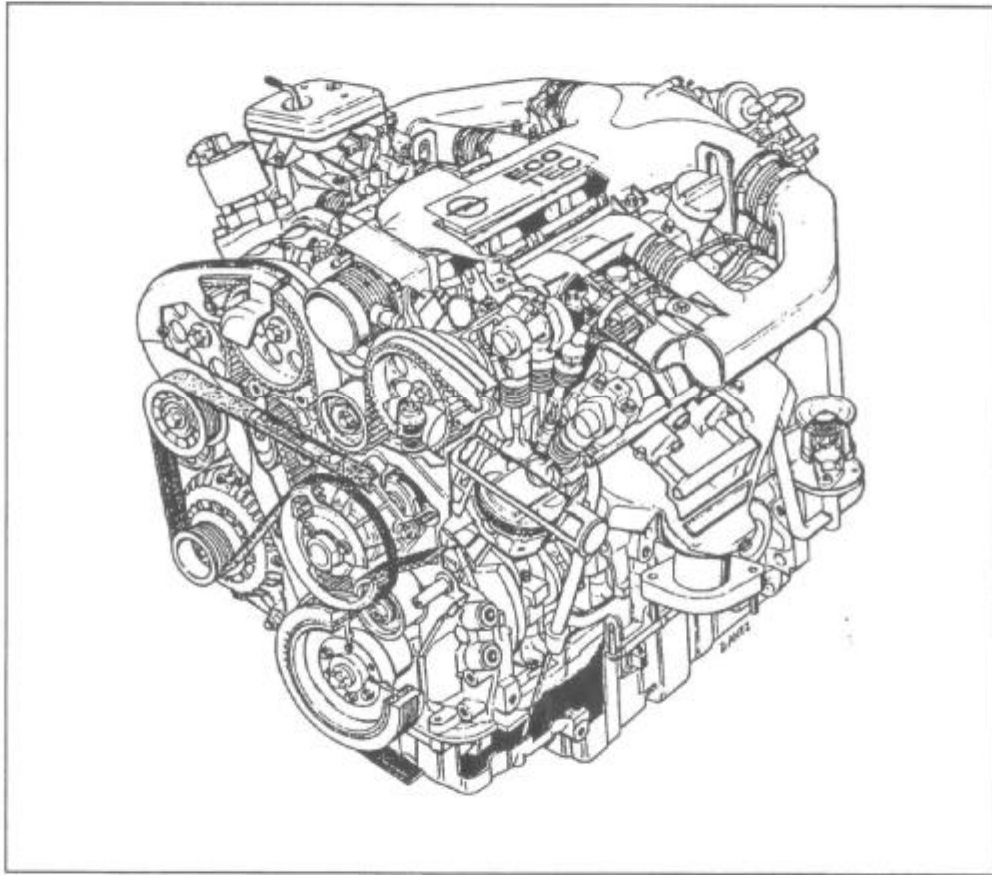

Similar to the X25XE (Omega B) with the following changes:

- Reworked cylinder heads to provide better torque and less valve noise.
- Redesigned inlet system
- Reworked engine management system - Motronic M2.8.3 with the following modifications:
 - New intake system
 - New idle air control
 - Changed connection sequence for the ignition cables to the DIS ignition module
 - Power steering pressure sensor (increases idle speed when steering wheel turns)
 - New control unit (hardware) with the following modifications:
 - New error codes and description
 - New 88 pin plug (new pin assignment)
 - Flash programming feature
- New one piece alloy oil pan

Vauxhall College - Multi-Valve V6 Engine

Basic strip down and rebuild is identical to sections 4, 5 and 6 with the following changes:

Remove Intake System

Detach vacuum hoses from vacuum accumulator (1) and remove accumulator from inlet manifold.

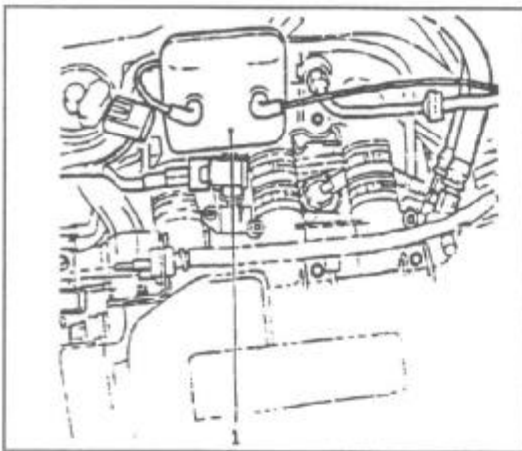

Release 5 hose clips from intake bridge side of hoses and remove 3 fastening screws from intake manifold 1,3,5 and remove manifold (2).

At this stage the spark plugs and leads can be removed if necessary.

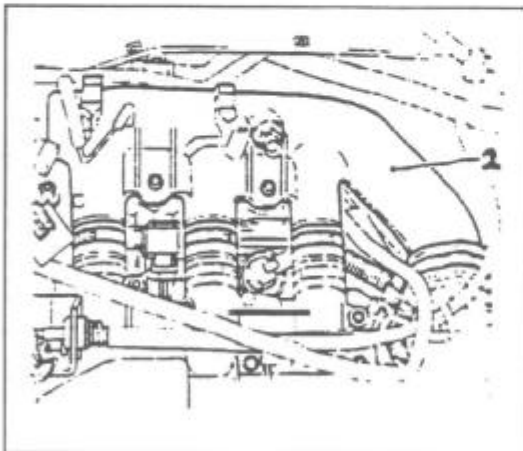

Repeat operation with intake manifold 2,4,6. Again, the sparkplugs and leads can be removed if necessary.

Detach coolant hoses (1) from metal pipes. Detach engine vent hoses (7) and (8) and vacuum hose (6) from throttle body.

Detach EGR corrugated pipe from EGR adaptor and one bolt from intake manifold support bracket to EGR adaptor.

Remove 4 fastening bolts from intake plenum and remove plenum from intake bridge.

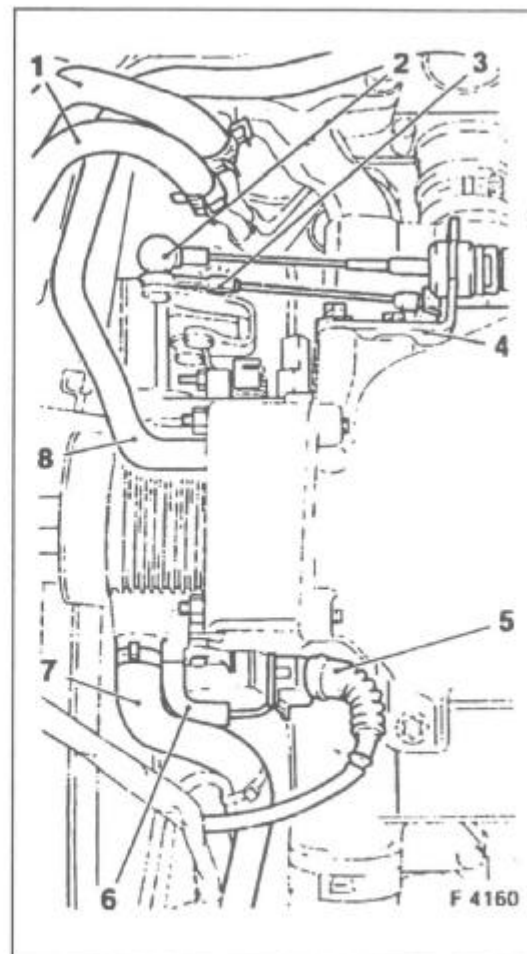

Vauxhall College - Multi-Valve V6 Engine

Disconnect wiring harness plugs from coolant temperature sensor and sender on coolant bridge. Remove 6 bolts from intake bridge and remove bridge (1) from intake flange.

Note: Fuel pressure regulator and fuel connections are at rear of engine (2).

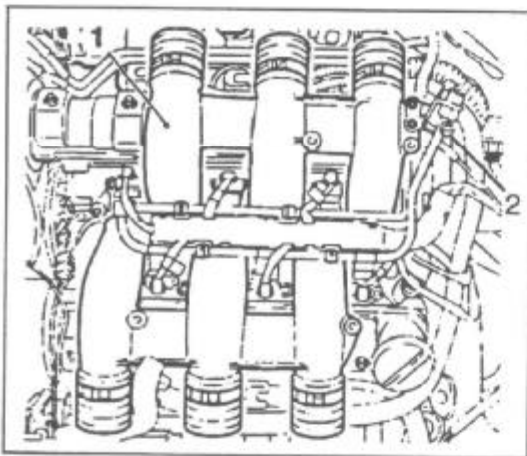

Remove intake manifold support brackets from cylinder heads. Remove coolant pipe screws from front bracket and vent housing and remove pipe (4). Remove spark plug leads.

Camshaft Covers

Camshaft covers are made from alloy, not plastic, but held by screws, as before (5).

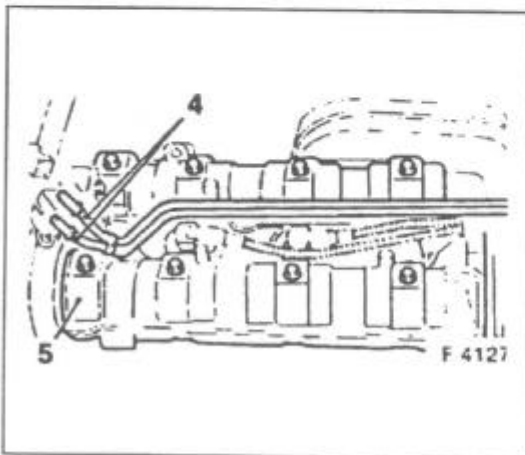

Reassembly is the reverse of disassembly.

Modified D.I.S. Ignition Coil

Note: The spark plug lead connection sequence is different on this engine to previous V6 engines - note the numbers on leads and D.I.S. coil.

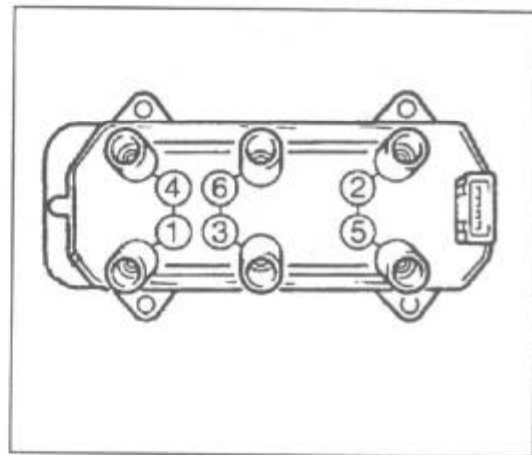

Oil Pan

The Vectra X25XE is equipped with a one piece alloy oil pan (3).

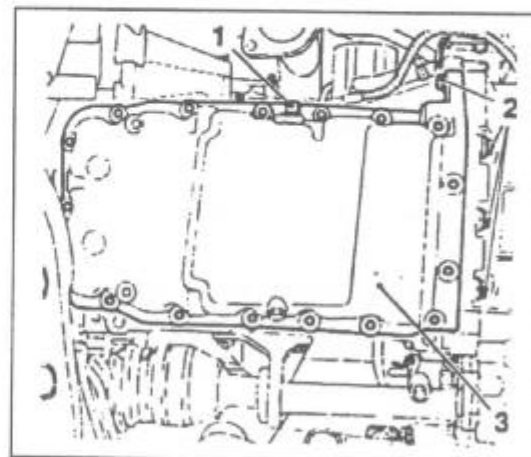

Vauxhall College - Multi-Valve V6 Engine

Wiring Harness Connectors

When removing connectors, note their position (1-9)

- 1 Throttle valve potentiometer
- 2 Power steering pump pressure sensor
- 3 Crankshaft pulse pick-up
- 4 Oxygen sensor (cylinders 2-4-6)
- 5 Camshaft sensor
- 6 Knock sensor (cylinders 2-4-6)
- 7 Knock sensor (cylinders 1-3-5)
- 8 Exhaust gas recirculation valve
- 9 Idle speed stepper motor

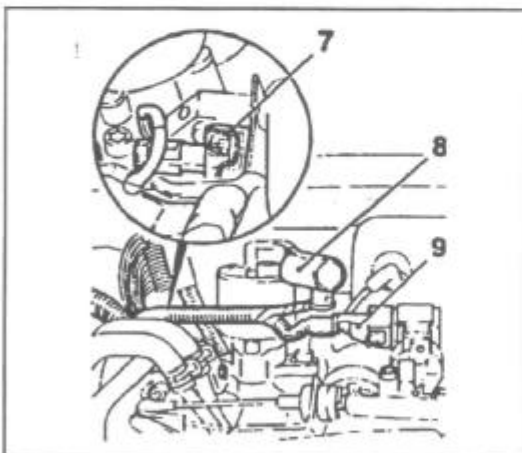
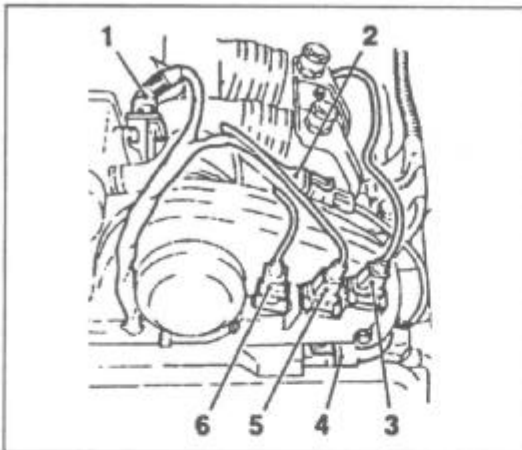

Vauxhall College - Multi-Valve V6 Engine

Section 11

Gas/Air Systems

Vauxhall College - Multi-Valve V6 Engine

X 25 XE & X 30 XE Exhaust Gas Recirculation System, V6 DOHC Petrol Engine

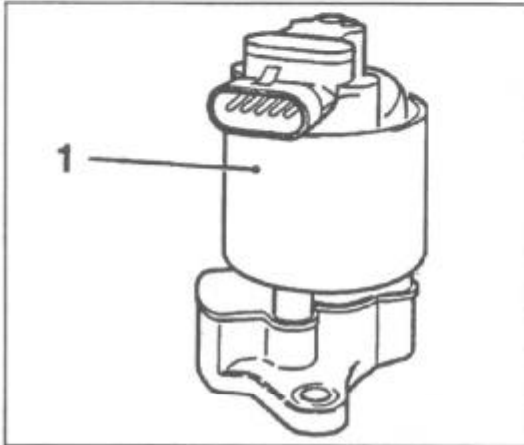

Exhaust Gas Recirculation Valve

Function

The exhaust gas recirculation valve is actuated directly by the Motronic M2.8.1.

If the exhaust gas recirculation valve is opened, exhaust gasses flow from the exhaust manifold, right engine side, through a corrugated pipe into the exhaust gas recirculation valve, and from there through a duct in the exhaust gas recirculation valve adapter into the intake tract.

The amount of exhaust gas is controlled by the control unit. The control unit measures engine parameters such as engine speed, load condition and temperature via the sensor input signals and calculates the desired exhaust amount.

A response potentiometer in the exhaust gas recirculation valve uses the position of the valve needle to report the opening cross section to the Motronic M2.8.1, guaranteeing precise dosage of the amount of exhaust gas being returned.

The returned exhaust gasses lower the oxygen content of the intake air. This in turn lowers the combustion temperature. The lower the combustion temperature is, the less noxious nitrogen oxide can be formed.

Service

If the exhaust gas recirculation valve, the lead between the exhaust gas recirculation valve and the control unit or the response potentiometer is defective, the engine telltale illuminates and a trouble code is stored in the control unit.

The exhaust gas recirculation valve can be checked using TECH 1 actuator diagnosis.

In case of a defect, the control unit continues operating with replacement values to ensure that the vehicle can reach the nearest authorised Vauxhall workshop.

Vauxhall College - Multi-Valve V6 Engine

Location of Exhaust Gas Recirculation System,
V6 DOHC Petrol Engine

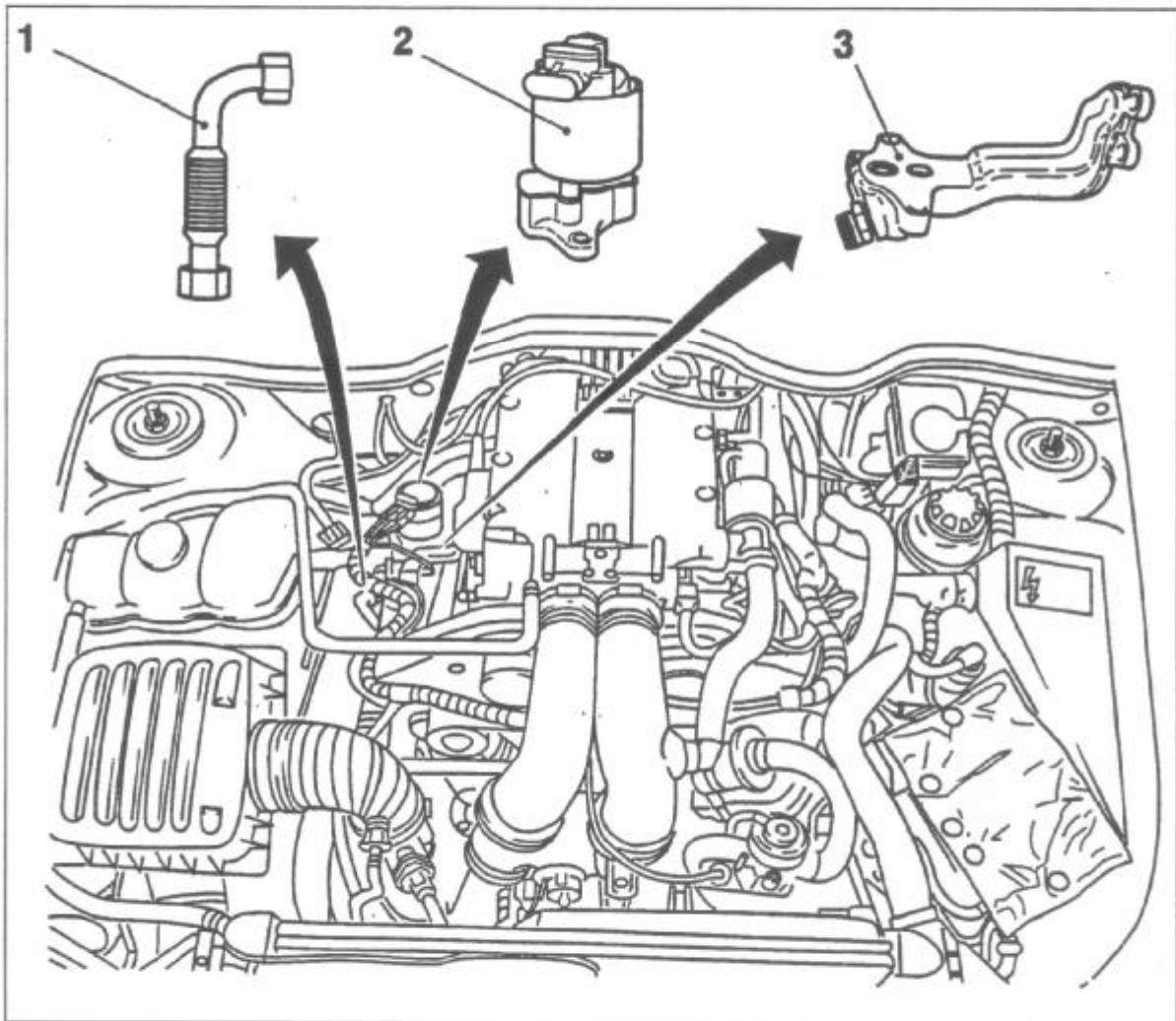

- 1 Corrugated pipe
- 2 Exhaust gas recirculation valve
- 3 Adapter, exhaust gas recirculation valve

Vauxhall College - Multi-Valve V6 Engine

Stereo Oxygen Sensor Loop

The stereo oxygen control consists of two separate oxygen sensor circuits, which regulate the carburation for the left and right cylinder banks.

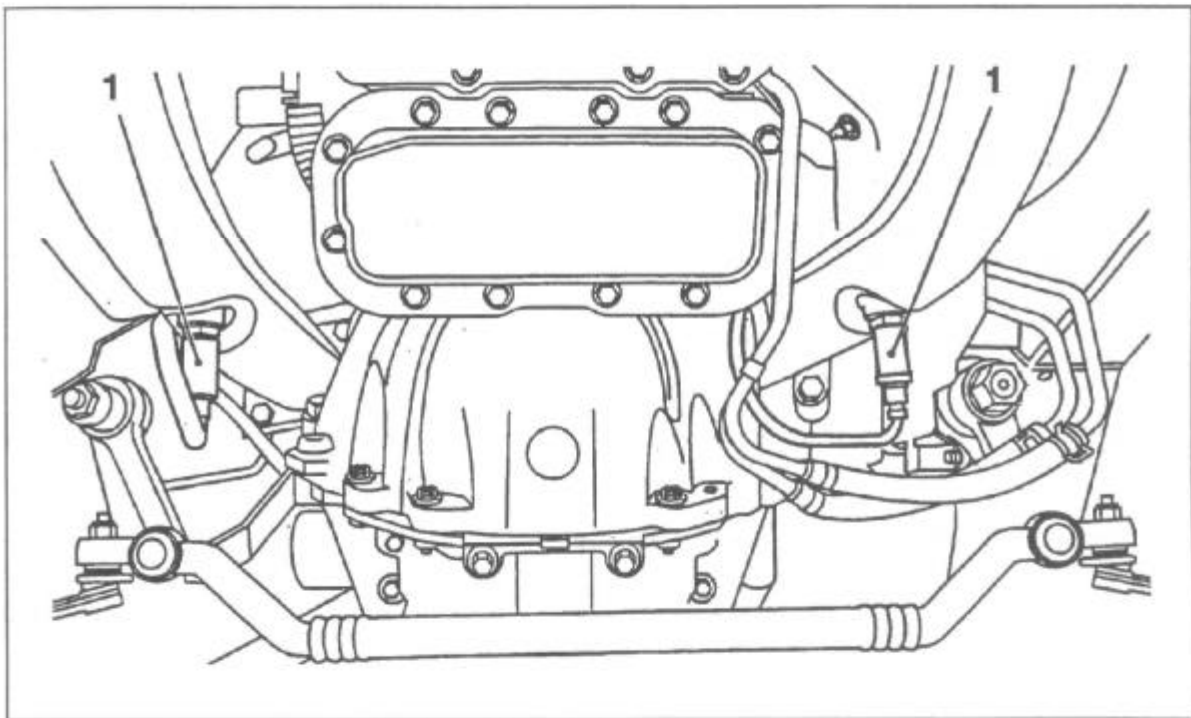

Oxygen Sensors

Function

The oxygen sensors measure the oxygen content of the left and right cylinder banks. If, for example, the mixture in the left cylinder bank is too rich (too little oxygen) and the mixture in the right cylinder bank is too lean (too much oxygen), the separate sensor circuits regulate the mixture leaner for the left cylinder bank and richer for the right cylinder bank.

Service

If O_2 sensor circuits 1 or 2, or the lead between O_2 sensors 1 and 2 are defective, or the mixture composition is incorrect, the engine telltale illuminates and a trouble code is stored in the control unit:

- Trouble code 13: O_2 sensor 1 lead interruption
- Trouble code 38: O_2 sensor circuit 1 voltage low
- Trouble code 39: O_2 sensor circuit 1 voltage high
- Trouble code 89: O_2 sensor circuit 2 voltage low
- Trouble code 91: O_2 sensor circuit 2 voltage high
- Trouble code 98: O_2 sensor 2 lead interruption

In case of a defect, the control unit continues operating with replacement values to ensure that the vehicle can reach the nearest authorised Vauxhall workshop.

Vauxhall College - Multi-Valve V6 Engine

Secondary Air Injection

The task of the secondary air injection, an emission control system, is to cause a reoxidation of exhaust gasses in the warm-up phase and shorten the catalytic converter response period. The injected air afterburns uncombusted particles in the exhaust gas.

Function

The electrically driven secondary air pump (installed in the front left wheel housing) injects clean air into the engine exhaust ducts, depending on the engine operating conditions.

The exhaust gasses are therefore reoxidised on their way to the catalytic converter, reducing the raw emission values for hydrocarbons (HC) and carbon monoxide (CO), the exhaust temperature is increased.

The catalytic converter and oxygen sensor attain their operating temperatures more quickly; oxygen sensor regulation operates earlier.

Secondary air injection is activated after starting. It does not have an independent control unit, but is controlled by the engine management.

The secondary air injection is switched off when oxygen sensor regulation is activated. *+ coolant temp*

The air current is controlled by a cutoff valve, which is opened and closed by an electric switch-over valve with intake manifold vacuum.

A non-return valve close to the engine prevents pressure build-up in the pipe system from reaching the secondary air pump.

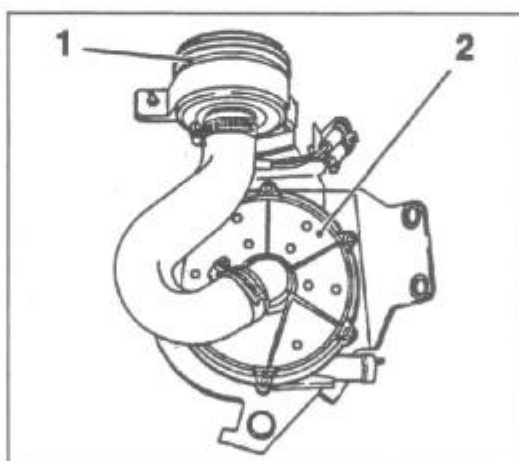

1 Air cleaner
2 Secondary air pump

Vauxhall College - Multi-Valve V6 Engine

Location of Components for Secondary Air Injection DOHC Petrol Engine

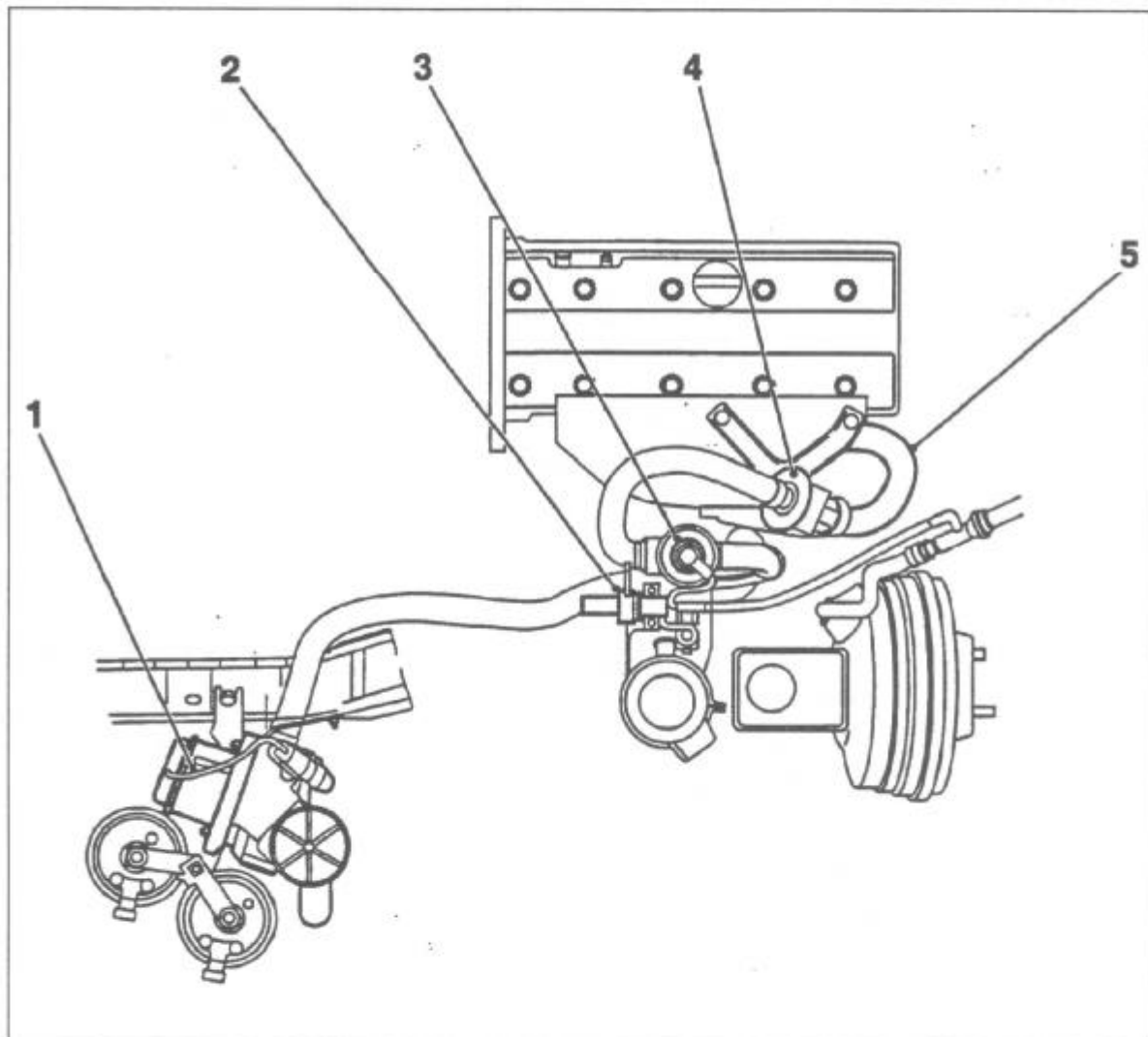

- 1 Secondary air pump, electric
- 2 Switch-over valve, electric
- 3 Cut-off valve, pneumatic
- 4 Non-return valve, pneumatic
- 5 Metal pipe

Vauxhall College - Multi-Valve V6 Engine

Location of Components for Secondary Air Injection DOHC Petrol Engines

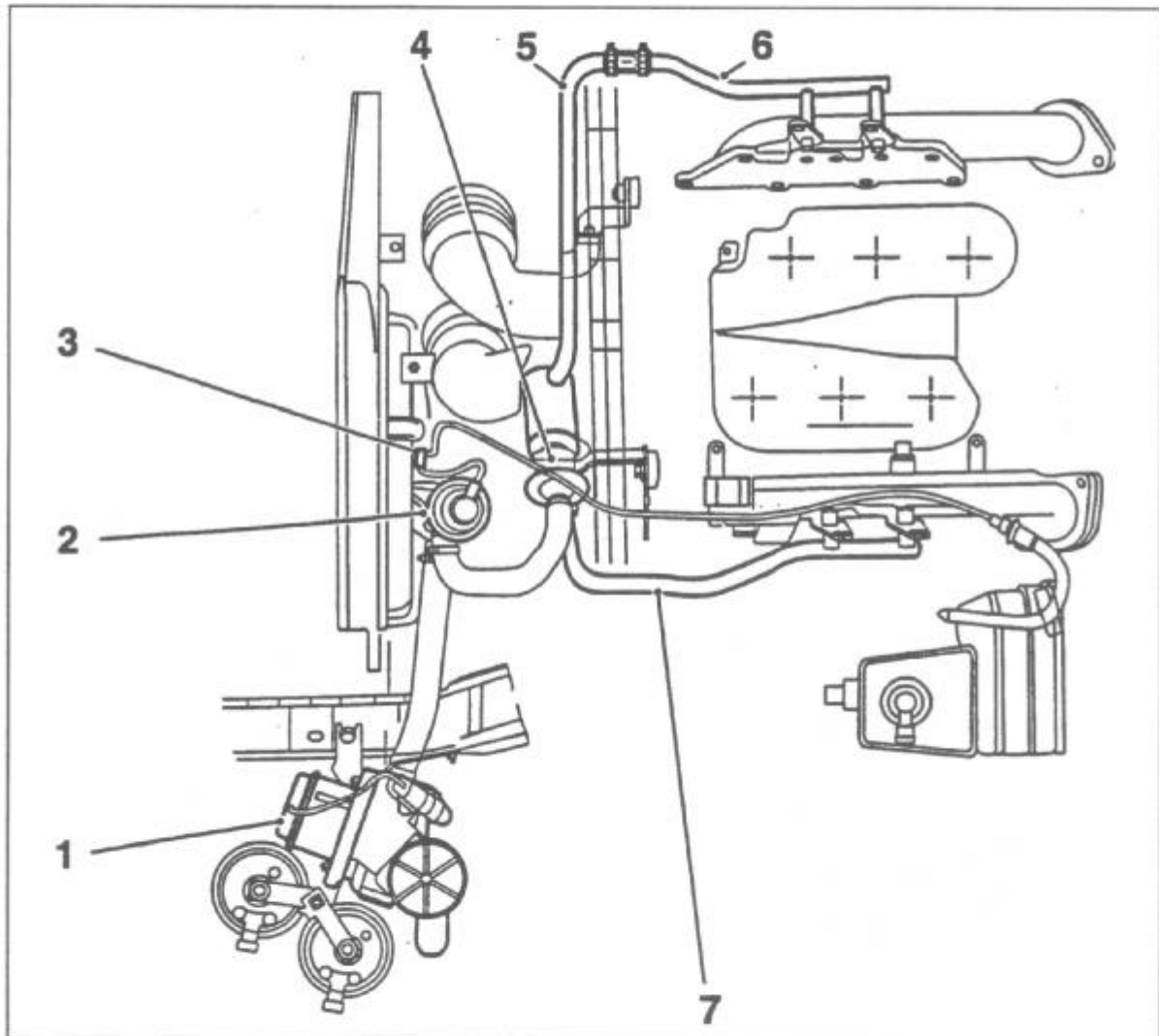

- 1 Secondary air pump, electric
- 2 Cut-off valve, pneumatic
- 3 Switch-over valve, electric
- 4 Non-return valve, pneumatic
- 5 Metal pipe, centre
- 6 Metal pipe, right side of body
- 7 Metal pipe, left side of body

Vauxhall College - Multi-Valve V6 Engine

Function Diagram, Secondary Air Injection

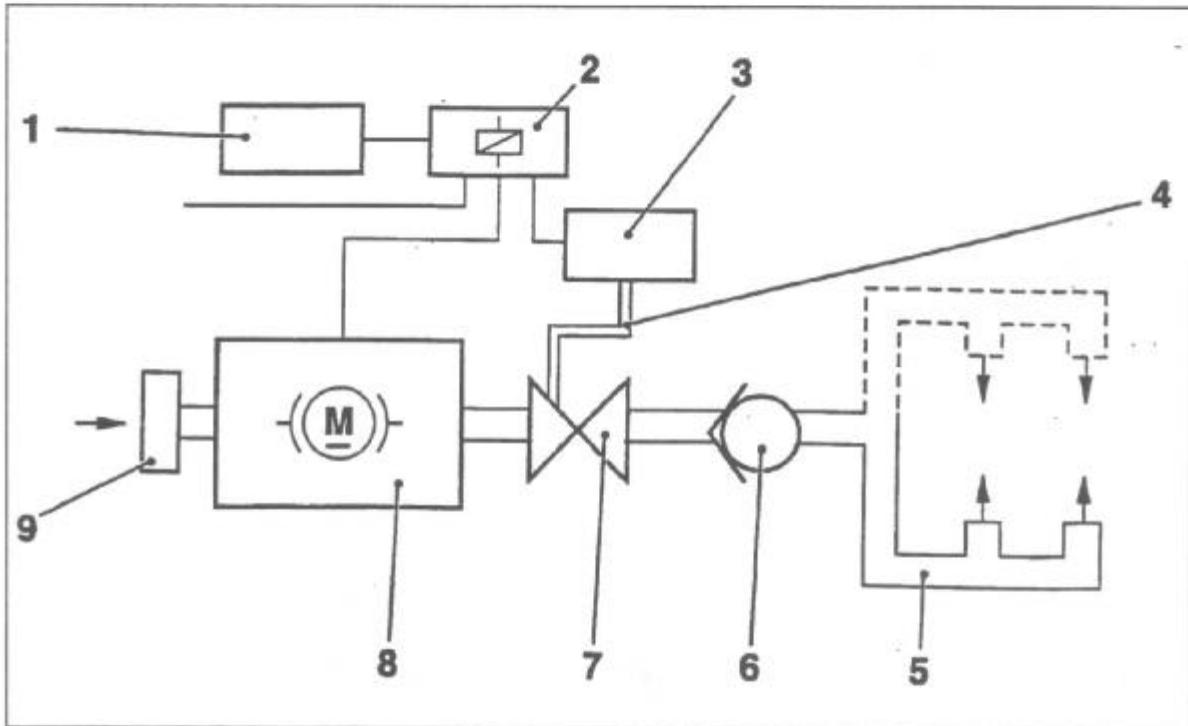

- | | |
|--|--------------------------------|
| 1 Control unit | 6 Non-return valve, pneumatic |
| 2 Relay, secondary air injection | 7 Cut-off valve, pneumatic |
| 3 Switch-over valve, electric | 8 Secondary air pump, electric |
| 4 Intake manifold pressure | 9 Air cleaner |
| 5 Engine (X 25 XE/X 30 XE shown with dotted lines) | |

Service

If a defect occurs in the secondary air pump relay, the engine telltale illuminates and a trouble code is set in the control unit.

The secondary air pump relay can be checked using TECH 1 actuator diagnosis.

In case of a defect, the control unit continues operating with replacement values to ensure that the vehicle can reach the nearest authorised Vauxhall workshop.

Vauxhall College - Multi-Valve V6 Engine

MULTI-RAM System

The MULTI-RAM System is a completely new intake system, developed from the DUAL-RAM system.

The intake manifold length is adapted to the engine by two valves instead of one to achieve high torque over a wide engine speed range.

The first valve (resonance pipe switch-over valve) is located between the intake pipes and can connect them to each other as required.

The second valve (intake plenum switch-over valve) is positioned in the intake plenum.

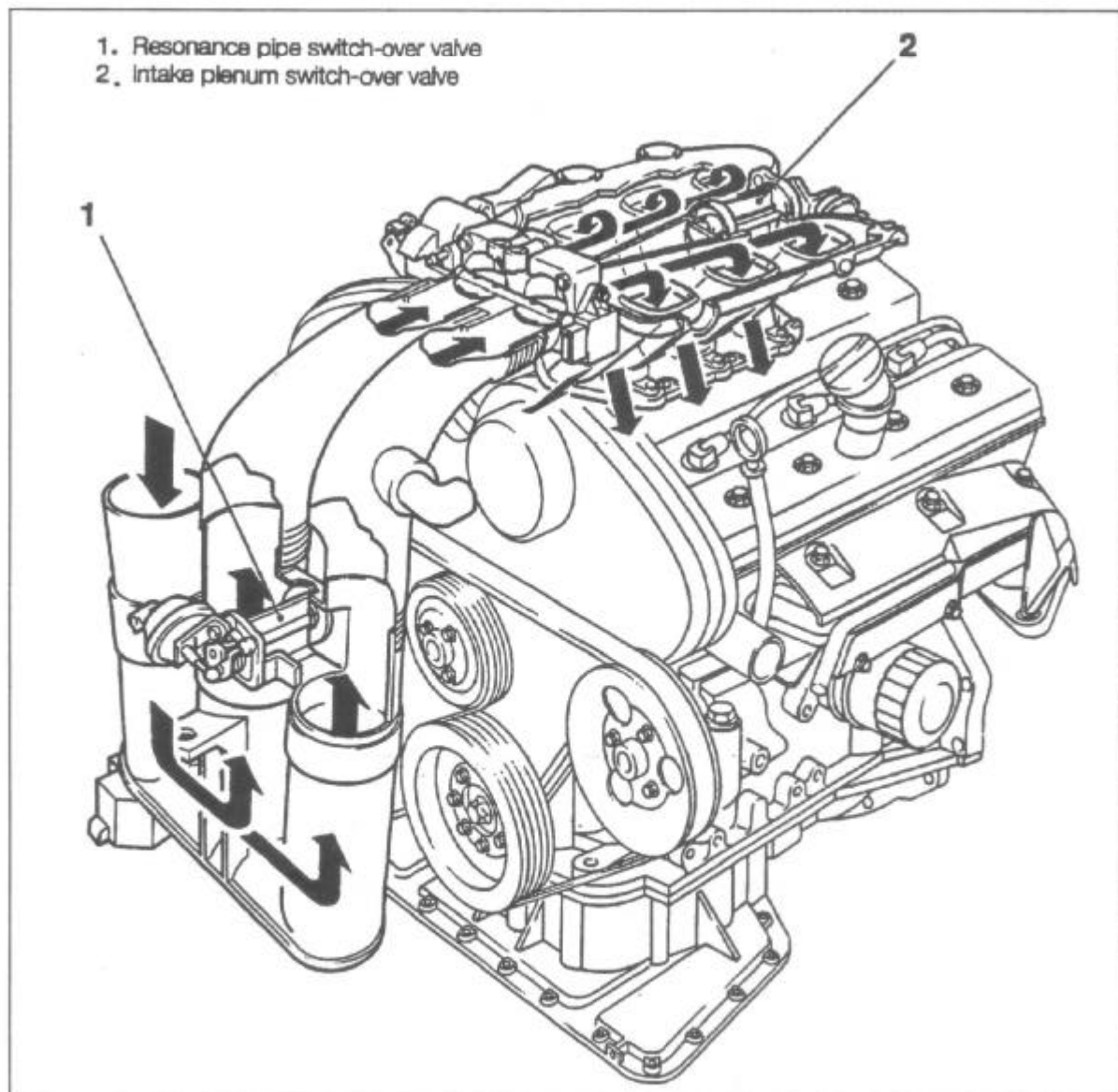

Vauxhall College - Multi-Valve V6 Engine

MULTI-RAM System cont.

Function

The valves are regulated by the Motronic via solenoid valve. The intake plenum switch-over valve and the resonance pipe switch-over valve are actuated by vacuum from the solenoid valves.

Actuation of the intake plenum switch-over valve and the resonance pipe switch-over valve lengthens or shortens the intake distance to optimise output progression. When the intake plenum switch-over valve is closed, the first torque peak is attained while the engine is still in the lower engine speed range.

The advantage over the DUAL-RAM system is the improved adaptation. Torque progression is even more regular and thus shift points are undetectable over the entire engine speed range.

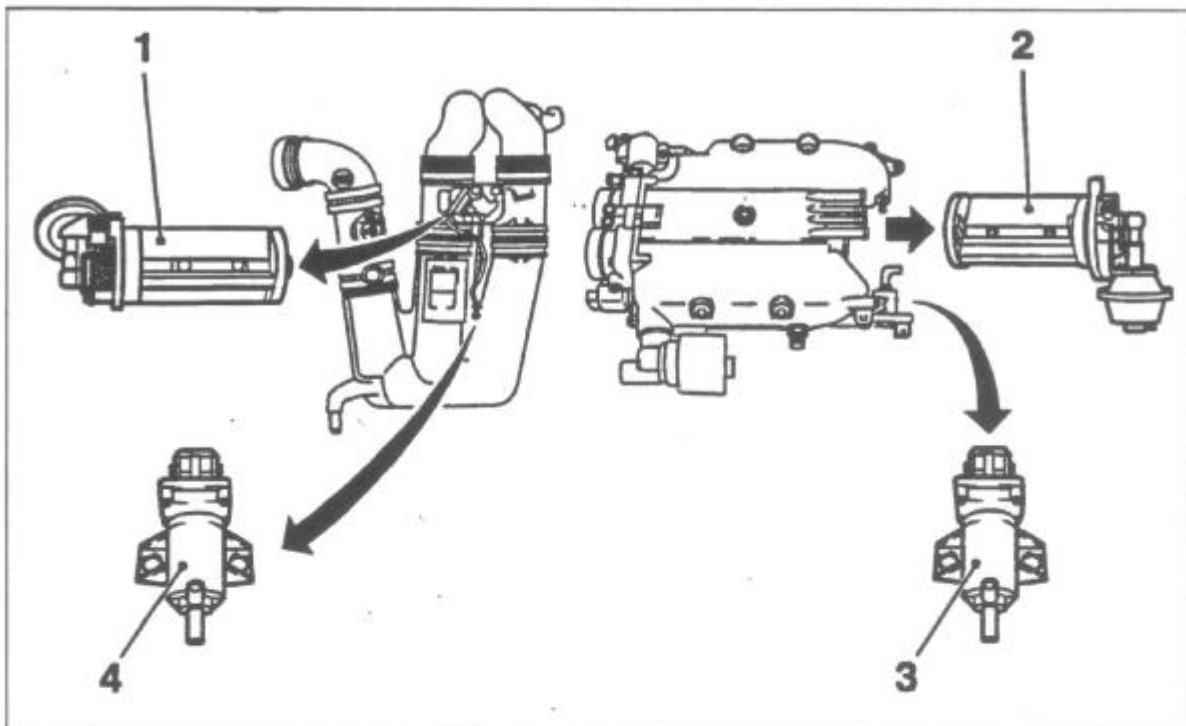

- 1 Resonance pipe switch-over valve
- 2 Intake plenum switch-over valve
- 3 Solenoid valve for intake plenum switch-over valve
- 4 Solenoid valve for resonance pipe switch-over valve

Vauxhall College - Multi-Valve V6 Engine

MULTI-RAM System cont.

Function Diagram

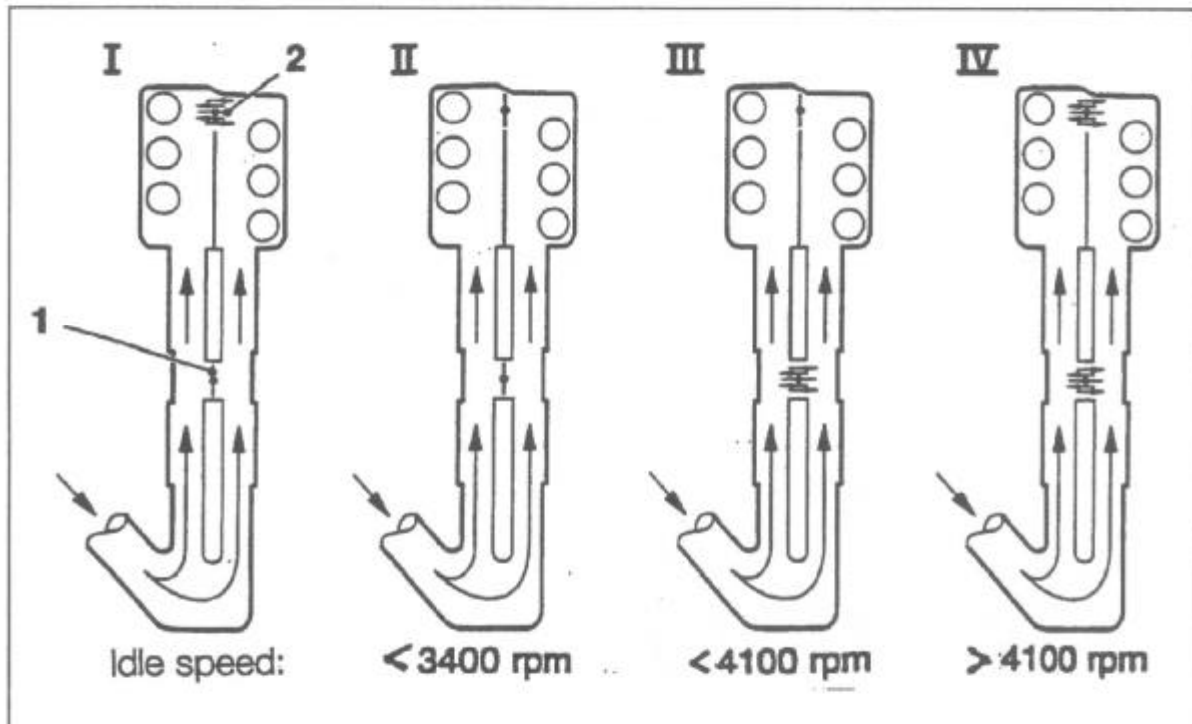

- 1 Resonance pipe switch-over valve
2 Intake plenum switch-over valve

Note:

When 'engine off', the resonance pipe switch-over valve (1) is closed and the intake plenum switch-over valve (2) is open.

Switch conditions:

I	=	Idle speed:	(1) closed, (2) open
II	=	Full load, lower engine speed range:	(1) closed, (2) closed
III	=	Full load, middle engine speed range:	(1) open, (2) closed
IV	=	Full load, upper engine speed range:	(1) open, (2) open

Vauxhall College - Multi-Valve V6 Engine

MULTI-RAM System cont.

Service

If intake manifold solenoid valve 1 or 2, the lead between intake manifold valves 1 and 2, or intake manifold valve 1 or 2 is defective, the engine telltale illuminates and a trouble code is stored in the control unit.

- Trouble code 59: intake manifold solenoid valve 1 voltage high.
- Trouble code 63: intake manifold solenoid valve 1 voltage low
- Trouble code 123: intake manifold valve 1 blocked
- Trouble code 124: intake manifold valve 2 blocked
- Trouble code 133: intake manifold solenoid valve 2 voltage high
- Trouble code 134: intake manifold solenoid valve 2 voltage low

In case of a defect, the control unit continues operating with replacement values to ensure that the vehicle can reach the nearest authorized Vauxhall workshop.

The intake manifold solenoid valve can be checked using TECH 1 actuator diagnosis.

Note:

At times, components have different designations in reference to TECH 1:

Intake manifold solenoid valve 1:	Solenoid valve for intake plenum switch-over valve
Intake manifold solenoid valve 2:	Solenoid valve for resonance pipe switch-over valve
Intake manifold valve 1:	Intake plenum switch-over valve
Intake manifold valve 2:	Resonance pipe switch-over valve

Vauxhall College - Multi-Valve V6 Engine

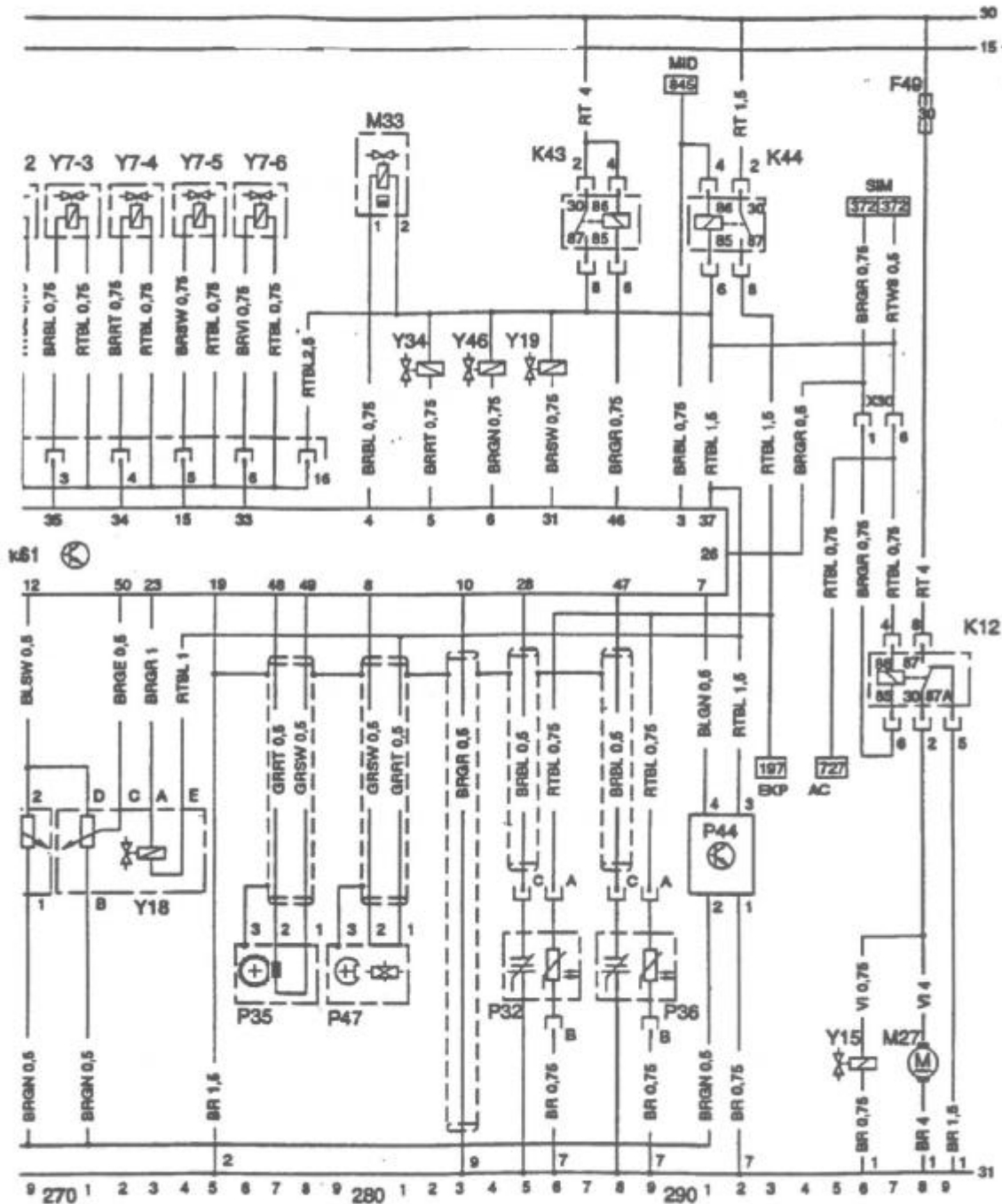

- | | |
|-------------------------------------|---------------------------------------|
| F 49 Fuse, secondary air injection | P 32 Heated oxygen sensor 1 |
| K 12 Relay, secondary air injection | P 36 Heated oxygen sensor 2 |
| K 43 Injection system relay | Y 15 Secondary air switch-over valve |
| K 44 Fuel pump relay | Y 18 Exhaust gas recirculation valve |
| K 61 Control unit, Motronic M 2.8.1 | Y 19 Intake manifold solenoid valve 2 |
| M 27 Secondary air pump | Y 46 Intake manifold solenoid valve 1 |